

TRANSIT VANS

Ford



Go Further



Visionary. Ingenious. Remarkable.
Every vehicle bears his signature.

Henry Ford





Built to carry the heaviest loads.

Whatever you need from a van, you'll find it in the Ford Transit. Three load lengths, two roof heights, a choice of FWD, RWD and AWD powertrains, GVMs between 2,900 kg and 4,700 kg, and GTMs up to 7,000 kg. Plus a choice of seating and bodystyle configurations to meet your needs.

Towing ability

Ford Transit's appetite for hard work extends beyond its loadspace. The 350HD and 470 versions with high-rated suspension, and 7,000 kg GTM can pull up to 3.5 tonnes of braked trailer load. (Commercial users may need a digital tachograph) (Option)



Loading made easy.

Behind Transit's DIN/ISO compliant bulkhead, you'll find up to 15.1 cu.m* of secure cargo space. Near-vertical side walls, a flat load floor and load lengths of up to 4217 mm in the L4 version mean standard-length items, such as pipes, boards and rolls of carpet can be carried with ease. Access is quick and simple, thanks to a wide-opening sliding side door, full-height rear doors and a built-in rear bumper step. While the tough, Easy To Clean Load Floor helps to protect your van and your load. (Option on Base, Standard on Trend)



Sidewall tie-downs

Transit has DIN/ISO compliant tie-down points positioned just above the floor on the side wall of the load space. This makes it easier to secure loads, while keeping the floor clear of obstructions, eliminating dirt traps and allowing the installation of the Easy To Clean Load Floor. (Standard)



Model shown is a Ford Transit Base L4 H3 with dual side load doors (option) load area protection kit (option) full-width DIN/ISO compliant bulkhead (standard) and LED loadspace lighting (option).
*Measured in cubic metres in the L4 H3 Van.



Double Cab-in-Van. The adaptable load carrier.

For an even more versatile Transit, look no further than the Double Cab-in-Van. Capable of carrying up to seven people, its standard bulkhead safely separates the load space from the passenger area.

Model shown is a Ford Transit Double Cab-in-Van Trend L3 H2 in Tectonic Silver metallic paint (option) with front mudflaps (option), and driver's sidesliding load doors (option).
Note: 180° rear cargo door hinge design appearance to change in Q3 2017.

Hard-working versatility

There's plenty of space for you, your crew and equipment in Transit Double Cab-in-Van. Carry a work team onsite in comfort with their tools stored safely in the versatile loadspace. A rubberised floor covering and half-height side trim reinforce its tough working credentials.



Your office on the move.

Light, bright and easy to drive, Transit sets the standard for vehicles in its class. With exceptional levels of finish and refinement, smart driver-oriented technology, plus a range of practical and thoughtful features – like a fold-down table that’s integrated into the dual front passenger’s seat and large enough to hold a laptop computer – it’s your office on the road.

Model shown is a Ford Transit Van Trend with Ford SYNC 3 navigation system (option), Lane-Keeping Alert (option) and front passenger’s* airbag (option).

Please note: It is an offence for drivers to use laptops, hand-held mobile phones or similar devices whilst driving.

*Note: A rear-facing child seat should never be placed in the front passenger seat when the Ford vehicle is equipped with an operational front passenger’s airbag.

SelectShift automatic transmission

Transit’s six-speed SelectShift automatic transmission delivers a smooth, relaxing driving experience, especially in busy stop-start traffic. The transmission allows you to change gear manually if you prefer, using the facia-mounted gearshift, and provides the ability to lockout gears in more challenging driving conditions, e.g. on slippery surfaces or steep gradients. (Option on front-wheel drive models)



Use your voice like another pair of hands.

New Ford SYNC 3 gives you control of everything from music to phone calls, apps and text messaging through simple voice commands. The intuitive 6" colour touchscreen lets you configure your home screen just how you want it, while Applink, Apple CarPlay and Android Auto, allow you to bring your smartphone HMI into your vehicle. Live Traffic** is available through the FordPass app connecting seamlessly via SYNC 3 with navigation*. Live Traffic gives you up-to-the-minute traffic data, enabling you to avoid congestion and save you time.

*Ford SYNC 3 navigation is optional.
**Live Traffic is free for 2 years.

Please note: Full SYNC 3 smartphone integration only available with iPhone 5/Android 5.0 (Lollipop) or higher. Some SYNC 3 functions require a data connection, so mobile data charges will apply. To check whether Apple CarPlay and Android Auto are available in your market, please check official Apple CarPlay and Android Auto websites for the latest information.

Note: 180° rear cargo door hinge design appearance to change in Q3 2017.



| SYNC

“Call John”

“Find town centre”

“Listen to message”



“I need fuel”

“I’m hungry”

“I need to park”



Designed for business, built for hard work.

Ford Transit's all-new 2.0-litre Ford EcoBlue is a completely new generation of advanced, high-performance diesel engines. More powerful, cleaner, refined and extremely efficient with low running costs†, Ford EcoBlue diesels build on the industry-leading performance and technology of our award-winning Ford EcoBoost petrol engines.

Key benefits include

- Fuel consumption and CO₂ emissions reduced by up to 13 per cent†
- Improved performance with low-rpm torque increased by 20 per cent†
- Computer-optimised engine design for minimum noise and vibration
- Lower nitrogen oxide (NOx) emissions in line with Euro6 standards

†Comparison made to the previous 2.2L Duratorq TDCi EU Stage 5 engine for the prior model.

New from the ground up, the all-new Ford EcoBlue diesel engine enhances fuel efficiency by up to 13 per cent compared with the previous 2.2-litre TDCi engine, with fuel consumption from 42.2 mpg* (6.7 L/100km*) and CO₂ emissions from 174 g/km*, while delivering significant improvements in low-rpm torque for enhanced driveability.

Each engine in the range – 105 PS, 130 PS and 170 PS – uses state-of-the-art design, including low friction technologies, ultra-high pressure fuel injection and the latest turbocharger and combustion technology to deliver low NOx emissions in line with stringent Euro6 standards. What's more, the new engine also benefits from up to 2-year/36,000 miles (whichever comes first) variable service intervals to help further reduce the cost of ownership.

105 PS NI from 42.2 mpg (6.7L/100 km*) 174 g/km. NEDC Combined Cycle test figures.

**55% less
NOx than the
previous
standard.**

Greater performance,
fewer emissions.

Transit's all-new 2.0-litre Ford EcoBlue diesel engines comply with the Euro6 emissions standard. A Selective Catalytic Reduction (SCR) system uses AdBlue®, a urea/water-based fluid to convert NOx emissions in the exhaust gas into nitrogen and water. A particulate filter then reduces more than 99% of emitted solid particulates from the vehicle's exhaust.

Choose the engine that's right for you.

More torque.
More pulling power.†

With more peak power and torque, and up to 20% more low-end torque than the equivalent prior-generation engine†, each of the 2.0-litre Ford EcoBlue engines provides excellent performance, both in terms of fuel economy and flexibility. A choice of three power and torque outputs means there's an engine to suit the demands of every job.

†Comparison made to the previous 2.2L Duratorq TDCI EU Stage 5 engine for the prior model.

360 Nm
105 PS
From **174 g/km****

More efficient†

All-new Ford EcoBlue 2.0L TDCi 105 PS

Engineered to meet Euro6 emissions standards, Transit's all-new 2.0-litre Ford EcoBlue 105 PS (77 kW)/360 Nm diesel engine combines outstanding fuel efficiency (from as low as 42.2 mpg* (6.7 L/100 km*) combined) with excellent driveability and refinement. Its state-of-the-art design helps to keep running costs down without compromising on payload or performance.

*105 PS NI from 42.2 mpg (6.7 L/100 km), 174 g/km. NEDC Combined Cycle test figures.

385 Nm
130 PS
From **174 g/km****

More flexible†

All-new 2.0L Ford EcoBlue 130 PS

The all-new 2.0-litre Ford EcoBlue 130 PS (96 kW)/385 Nm Euro6 diesel engine strikes a balance of delivering extra power and torque necessary to enhance Gross Train Mass (GTM) without compromising emissions.

**130 PS from 174 g/km. NEDC Combined Cycle test figures.

405 Nm
170 PS
From **179 g/km*****

More powerful†

All-new 2.0L Ford EcoBlue 170 PS

The outstanding all-new 2.0 litre Ford EcoBlue 170 PS (125 kW) Euro6 diesel engine develops an extraordinary 405 Nm of torque. As the most powerful engine in the range, its hard-working character makes it the ideal choice for moving heavy loads and towing, while still delivering outstanding fuel efficiency (from as low as 40.9 mpg*** (6.9 L/100 km***)) combined).

***170 PS from 40.9 mpg (6.9 L/100 km), 179 g/km. NEDC Combined Cycle test figures.



105 PS (77 kW) all-new 2.0L Ford EcoBlue

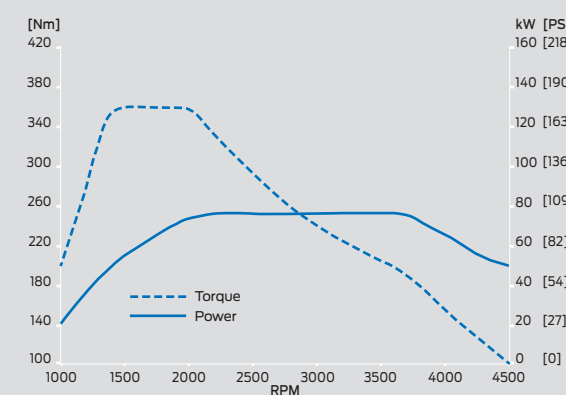

130 PS (96 kW) all-new 2.0L Ford EcoBlue

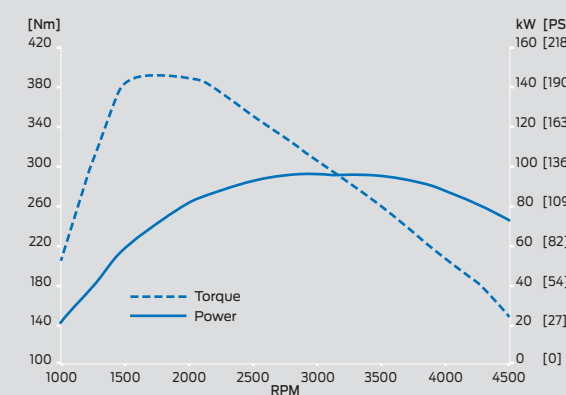

170 PS (125 kW) all-new 2.0 Ford EcoBlue

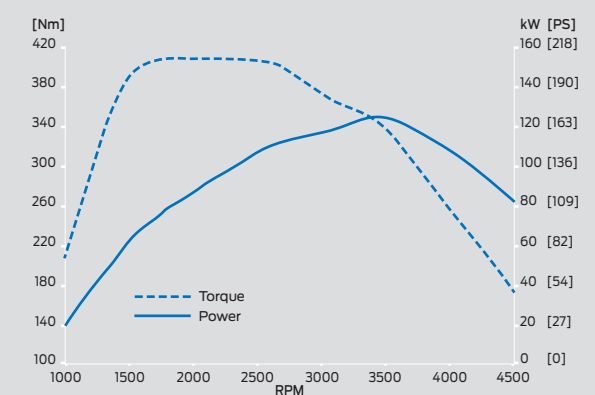

All-wheel drive confidence.

When the going gets tough, nothing beats the sure-footed performance of all-wheel drive. Available on selected models*, Transit's latest intelligent AWD system has been specially engineered to deliver optimum traction and enhanced stability in combination with the all-new Ford EcoBlue diesel engine. Together with the new engine's increased levels of low-end torque, the latest generation AWD system enables drivers to achieve smoother, more confident progress on challenging surfaces.

Optimise your drive.

Transit's all new 2.0-litre Ford EcoBlue diesel engine is offered with a choice of three power and torque outputs, each driving through a 6-speed manual transmission. All engines comply with Euro 6 emissions standards. Selected engines are available with Front-, Rear- or All-wheel drive.



Front-wheel drive

- Engine availability: 105PS/360Nm; 130PS/385Nm; or 170PS/405Nm
- Larger loadspace, extra interior height and lower load height
- Lower kerbweight for greater payload and fuel efficiency
- 6 speed automatic transmission available as an option (130PS and 170PS engines)

Rear-wheel drive

- Engine availability: 105PS/360Nm; 130PS/385Nm; or 170PS/405Nm
- Superior traction when heavily laden
- Best suited for heavier duty applications and towing

All-wheel drive

- Engine availability: 130PS/385Nm; or 170PS/405Nm
- New fourth-generation driver-selectable AWD system provides extra traction in difficult terrain conditions
- Under normal conditions drive is directed to the rear wheels. When engaged, the system automatically increases engine torque to the wheels with the most grip

All-wheel drive, for all-weather working

Transit's latest all-wheel drive (AWD) system automatically distributes engine torque to the front and rear wheels using a specially developed electronically-controlled AWD coupling. In conjunction with the vehicle's ESC system, the front/rear torque distribution can be varied between 0:100 and 50:50. Two modes are provided, with the standard AWD Auto mode suitable for most driving situations, and an AWD Lock mode that enhances traction in more extreme driving situations such as deep sand or deep snow.

*All-wheel drive is available on 350 L2/L3 Van; and Double Cab-in-Van 350 L2/L3.





The sum of all parts adds up to less cost.

Quality and durability are built into the Transit at every step. After many years of service it will feel as good, and be as rewarding to drive, as the day you picked it up.

Extended variableservice intervals of up to 36,000 miles or two years (whichever comes first) help further reduce your running costs.

Engine oil monitor warning light will illuminate if the condition of the engine oil deteriorates between services. (Standard)

High-level light units are mounted above the bumper line, to help keep them out of harm's way and protect them from low speed accident damage. (Standard)

Brake pad wear sensors warn when the pads are due for renewal. (Standard)

Fuel filter sensor warns of water ingress or a blockage of the fuel system. (Standard)

Ford Easy-Fuel capless refuelling system – a unique safeguard ensures that nobody can accidentally fill up with the wrong fuel. Plus, no dirty fuel caps to touch. (Standard)

12-year perforation warranty provides reassurance against perforation of the bodywork from the inside of the panel. (Standard)

Multi-piece rear bumper design helps to keep repair costs low. (Standard)

Note: 180° rear cargo door hinge design appearance to change in Q3 2017.

Go further for less.

Transit's all-new 2.0 Ford EcoBlue diesel engines are among the most refined and efficient available.

Featuring the latest technology, they not only offer strong, dependable performance, but deliver excellent fuel consumption and CO₂ emissions too.

Ford ECONetic Technology

Ford ECONetic Technology brings together a range of vehicle features and technologies to deliver improved fuel economy, reduced emissions and lower cost-of-ownership, without compromising on performance or functionality.

Ford ECONetic Technologies include

- All-new 2.0L Ford EcoBlue advanced diesel engines – provide exceptional fuel economy and low CO₂ emissions
- Ford Auto-Start-Stop – automatically switches off the engine when you come to a halt and put the vehicle in neutral. Restarts when you want to move off, reducing fuel consumption and exhaust emissions (Option. Standard on modes with automatic transmission)
- Ford Smart Regenerative Charging – charges the battery only when needed
- Gear Shift Indicator – advises driver of optimum time to change gear
- Ford Eco Mode – encourages economical driving behaviour
- Acceleration Control – a unique engine calibration designed to limit acceleration when the vehicle is lightly laden, helping to reduce fuel consumption (option)
- Ford Battery Management System – improves battery life, fuel consumption and ensures ready-to-go reliability

Model shown is a Ford Transit Trend L3 H2 in Moondust Silver metallic paint. (option)

Note The availability of Ford ECONetic Technology varies by model. Please ask your Ford Transit Centre for details. For more information on our sustainability initiatives visit www.ford.com/go/sustainability

When there's no time to think, Transit's already reacted.

Using radar and a camera, **Pre-Collision Assist**⁽²⁾

keeps a watchful eye on the road ahead. The system is designed to detect other vehicles and can alert you to a potential collision. If you don't respond to the system's warning signals,

Active Braking⁽²⁾ pre-charges the braking system and can automatically apply the brakes to help avoid or reduce the effect of any impact. (Option)



Driver Alert⁽²⁾

Designed to warn you if the system detects driving behaviour that indicates a drop in alertness levels. Initially, a warning icon is displayed in the instrument cluster, followed by a warning chime if driving alertness further declines. (Option as part of a pack)

⁽¹⁾Uses sensors.

⁽²⁾Operates at speeds over 45 mph on multi-lane roads with clearly visible lane markings.

⁽³⁾Safety feature.

⁽⁴⁾Driver assistance feature.

Note: 180° rear cargo door hinge design appearance to change in Q3 2017.



Lane Keeping Alert⁽¹⁾⁽²⁾

It only takes a momentary slip in concentration to drift out of your lane when driving on the highway. Lane Keeping Alert⁽¹⁾ is designed to recognise when you approach the road markings without using the indicator, and alerts you with vibrations through the steering wheel. (Option, standard on 350HD and 470 models)



Adaptive Cruise Control⁽²⁾

Set your desired speed and Adaptive Cruise Control maintains a pre-set distance from the vehicle in front. If the sensors detect traffic slowing ahead, your vehicle automatically slows down. When traffic has cleared, your vehicle accelerates back to the pre-selected speed. (Option on Trend as part of a pack)



Traffic Sign Recognition⁽²⁾

Designed to automatically read standard format road-speed signs and display the posted speed limit in the instrument cluster. (Option on Trend as part of a pack)



Delivers with confidence.

Ford Transit is fitted with our innovative Curve Control technology⁽²⁾. The feature – part of Transit's standard Electronic Stability Control⁽²⁾ system – is designed to sense when a driver takes a curve too quickly and can rapidly reduce engine torque, and apply brakes to individual wheels, to help keep the vehicle safely under control.

Further ESC features include

- Curve Control
- Traction Control System
- Hill Start Assist
- Trailer Sway Control
- Load Adaptive Control (LAC)
- Emergency Brake Assist (EBA)
- Emergency Brake Warning
- Roll Stability Control (RSC)
- Torque Vectoring Control
- Side Wind Stabilisation

Side Wind Stabilisation⁽²⁾

Helps the driver to stay in lane in strong, gusty conditions by using the ESC system to sense when the vehicle is being affected by crosswinds.

⁽¹⁾Uses sensors.

⁽²⁾Safety feature.

⁽³⁾Driver assistance feature.

Note: 180° rear cargo door hinge design appearance to change in Q3 2017.



Side curtain airbags⁽¹⁾
Designed to help protect the driver and front passenger's heads from injury. (Option)



Van
Medium wheelbase L2

Standard roof H2
FWD
10.0
cu.m*

RWD/AWD
9.5
cu.m*



High roof H3
FWD
11.2
cu.m*

RWD/AWD
10.7
cu.m*

2/3
seats

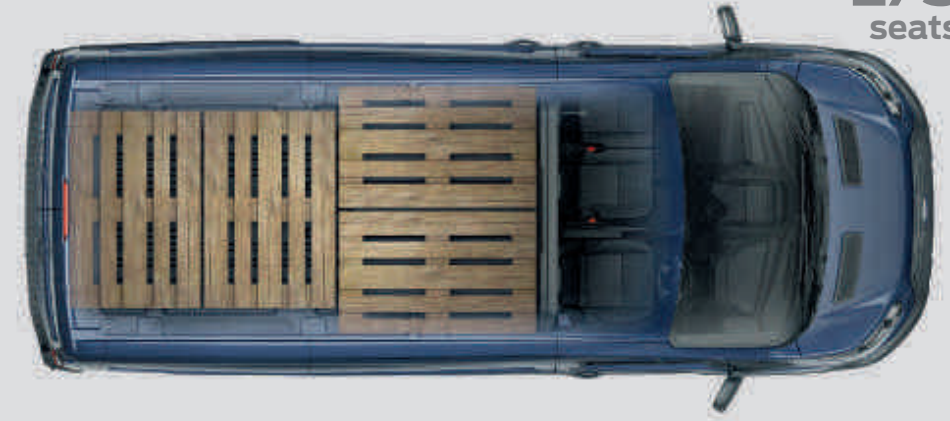

Van
Long wheelbase L3

Standard roof H2
FWD
11.5
cu.m*

RWD/AWD
11.0
cu.m*



High roof H3
FWD
13.0
cu.m*

RWD/AWD
12.4
cu.m*

2/3
seats

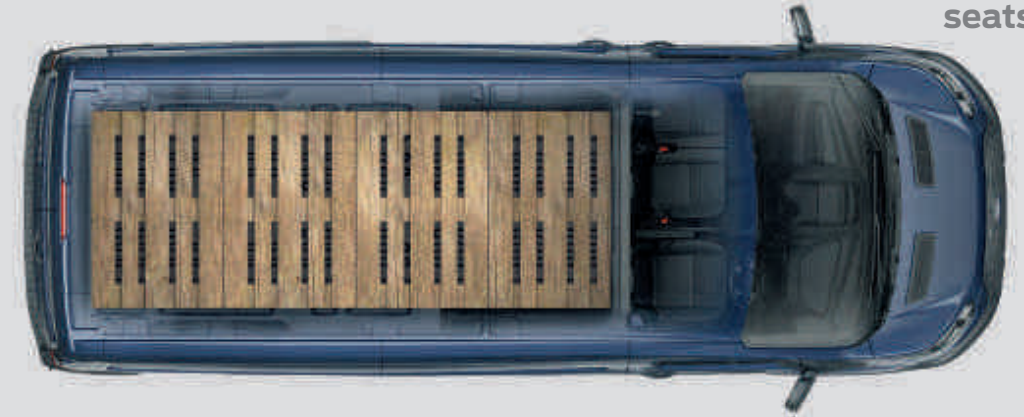

Van
Long wheelbase EL L4



High roof H3
RWD
15.1
cu.m*

2/3
seats

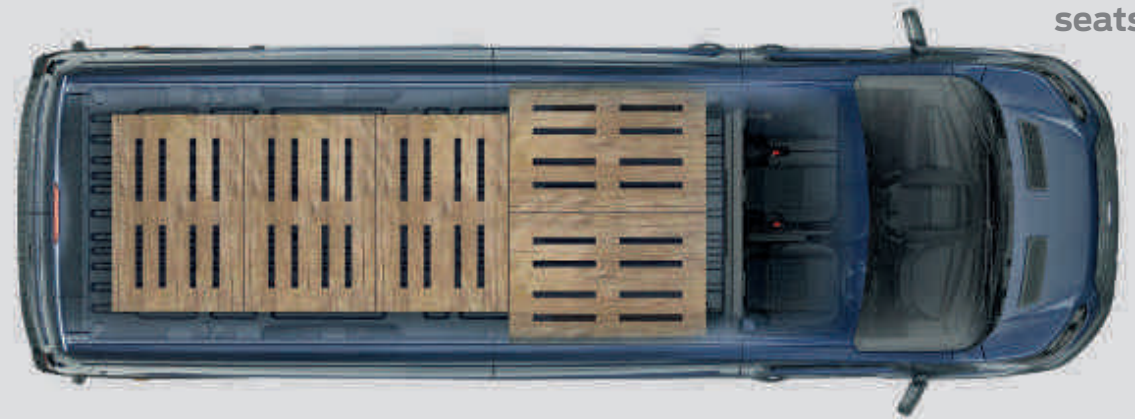

Transit Van.
Maximum load-carrying space and capacity.

Ford Transit Van clearly means business. Choose from three load lengths, plus a range of GVMs and driveline configurations.



Note: 180° rear cargo door hinge design appearance to change in Q3 2017.

*Measured in cubic metres and with a full bulkhead fitted.

Double Cab-in-Van
Medium wheelbase L2

Standard roof H2
FWD

6.1
cu.m*

RWD/AWD

5.7
cu.m*



High roof H3

FWD
6.7
cu.m*

RWD/AWD

6.4
cu.m*

5-6**
seats

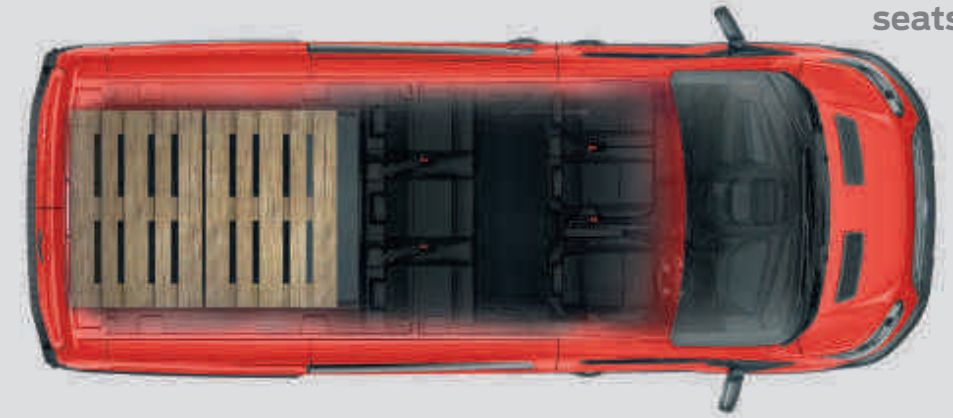

Double Cab-in-Van
Long wheelbase L3

Standard roof H2
FWD

7.6
cu.m*

RWD/AWD

7.2
cu.m*



High roof H3

FWD
8.4
cu.m*

RWD/AWD

8.0
cu.m*

5-7**
seats

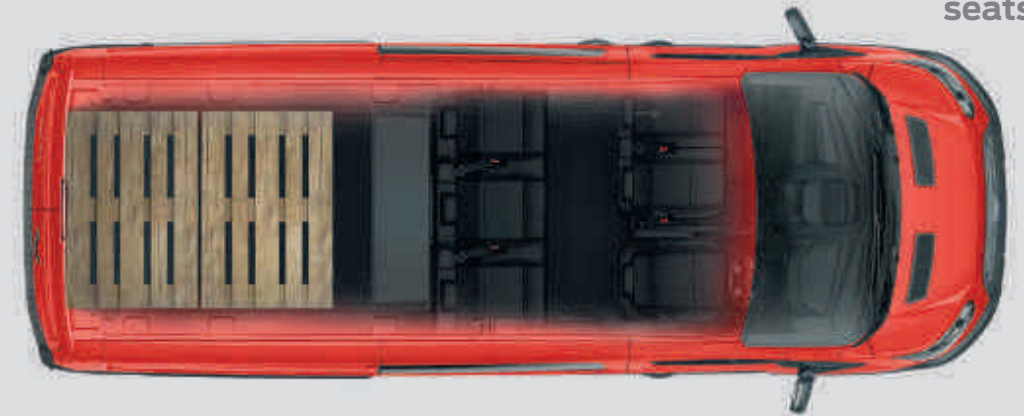

Double Cab-in-Van
Long wheelbase EL L4



High roof H3

RWD
10.6
cu.m*

5-6**
seats

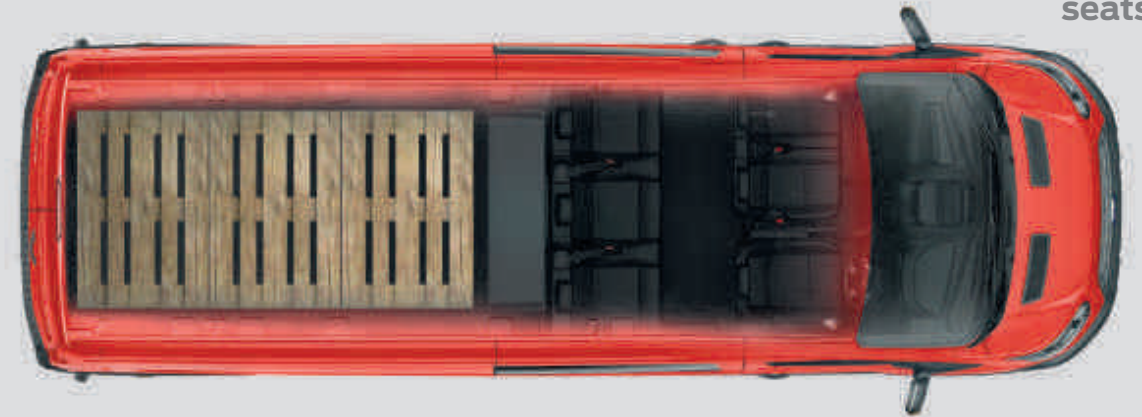

Double Cab-in-Van.
Secure transportation for people and their gear.

There's simply no finer crew-van than Ford Transit Double Cab-in-Van. Purpose-built to carry up to 7 people in combination with up to 10.6 cu.m of flexible loadspace behind a secure bulkhead, it can tackle virtually any task that comes its way.



*FWD/RWD and AWD. Maximum load volume measured in cubic metres and with a full bulkhead fitted.
**L2 and L4 models are only available with standard triple wide second row seat, L3 is available with optional second row quad seat.

Note: 180° rear cargo door hinge design appearance to change in Q3 2017.



Ford Easy-Fuel capless refuelling system
(Standard. Available as an option for capped systems)



Image above Ford Transit Van Base in Moon dust Silver metallic paint (option).
Note: 180° rear cargo door hinge design appearance to change in Q3 2017.

Base

Exterior features

- Door mirrors with large blind spot eliminator
- Door mirrors with integrated side indicators
- Passenger's side sliding load door
- Half cap wheel covers
- Headlight courtesy delay
- Integrated rear bumper step
- Wide bodyside mouldings
- Rear mudflaps
- Tyre inflator kit (SRW only)
- Sterling Grey front grille

Interior features

- Dual passenger's seat with underseat stowage compartment
- Electrically operated front windows
- Remote central locking
- My Connection radio with Bluetooth®, USB/iPod® connectivity and remote controls
- Trip computer
- Driver's 8-way seat adjust
- Rake - and reach - adjustable steering column
- Gear Shift Indicator
- Courtesy lights with theatre dimming
- Easy-clean rubber floor covering in cab
- Full width DIN/ISO compliant bulkhead (Van only)
- DIN 75410 compliant tie-down loops

Option Packs

- Auto-Start-Stop system (not available on AWD models)
- Low Visibility Pack (contents include heated windscreen, washer fluid sensor and electrically-operated and heated door mirrors)
- Lane Keeping Alert (may include additional equipment, refer to price list for further details) (standard on 350HD and 470 models)

For further option availability, please refer to the specification section.

Engines

- 105 PS (77 kW)/360 Nm
- 130 PS (96 kW)/385 Nm
- 170 PS (125 kW)/405 Nm

Bodystyles

- Van
- Double Cab-in-Van



Image right Ford Transit Van Base with Traxon and Max in Charcoal Black interior.



Parking distance sensors, front and rear
(Standard)



Image above Ford Transit Van Trend in Tectonic Silver metallic paint (option).
Note: 180° rear cargo door hinge design appearance to change in Q3 2017.

Trend

Exterior features in addition to Base

- Heated windscreen
- Automatic headlights
- Autowipers
- Front and rear parking distance sensors
- Electrically-operated/heated power foldable door mirrors
- Full wheel covers (with single rear wheels)
- Projector-style halogen reflector lights with static cornering lights
- Front fog lights
- Titanium effect front grille
- Twin remote keys

Interior features in addition to Base

- Ford SYNC radio/CD with Bluetooth®, USB/iPod® connectivity and steering wheel controls
- Leather-trimmed 4-spoke steering wheel
- Cruise control with Adjustable Speed Limiter
- Dual passenger's seat with lift-up seat stowage and fold-out table
- Map reading courtesy lights
- Passenger side load door footwell illumination
- Easy To Clean Load Floor
- Complete load compartment half-height trim board

Note The Bluetooth® word mark and logos are owned by the Bluetooth SIG, Inc. and any use of such marks by Ford Motor Company Limited and its associated companies is under licence. Other trademarks and trade names are those of their respective owners.

Option Packs

- Premium Visibility Pack (contents include rear-view camera and Lane Keeping Alert)
- Lane Keeping Alert (standard on 350HD and 470 models)
- Adaptive Cruise Control with Collision Mitigation, Emergency Brake Assist and Speed Sign Recognition

For further option availability, please refer to the specification section.

Engines

- 105 PS (77 kW)/360 Nm
- 130 PS (96 kW)/385 Nm
- 170 PS (125 kW)/405 Nm

Bodystyles

- Van
- Double Cab-in-Van

Image right Ford Transit Van Trend with Lane and Max in Charcoal Black interior.



Options and accessories

Storage solutions, extra protection and greater versatility are all available for Ford Transit.

Engine undershield

Tough corrosion-resistant metal undershield protects engine from accidental stone and kerb damage. Easily removed for oil changes and routine servicing. (Option and accessory)

Rubber floor mats

Equipped with the Transit nameplate. All-weather floor mats are tailor-made to fit your Ford perfectly and protect against dirt and damp. Securely fixed directly onto the vehicle's floor, the driver's mat cannot slip and interfere with the pedals. (Accessory)

Q-Top** (Q-Tech) roof gallery

Lightweight aluminium construction allows additional load*. Ideal for transportation of large, long or bulky items and gives you more flexibility in your daily business. Also available with a ladder roller at the rear end for easier loading. (Accessory)

*Please refer to vehicle weight and load specification.

Rear ladder

For easy access to the roof. Not available on L4 or models with optional 236 degree doors. (Option and accessory)

Rear window protection grille

Grille fixes to inside of rear windows for enhanced security without obscuring rearward vision. (Accessory)

Roof base carrier, lockable

Roof carrier holds up to 150 kg (depending on vehicle specifications) and is the base for various roof transportation attachments. (Accessory)



Interior roof rack

Two black steel racks hold a maximum of 50 kg and can be fixed in different locations on the inside roof rails in line with the flex floor. (Accessory)

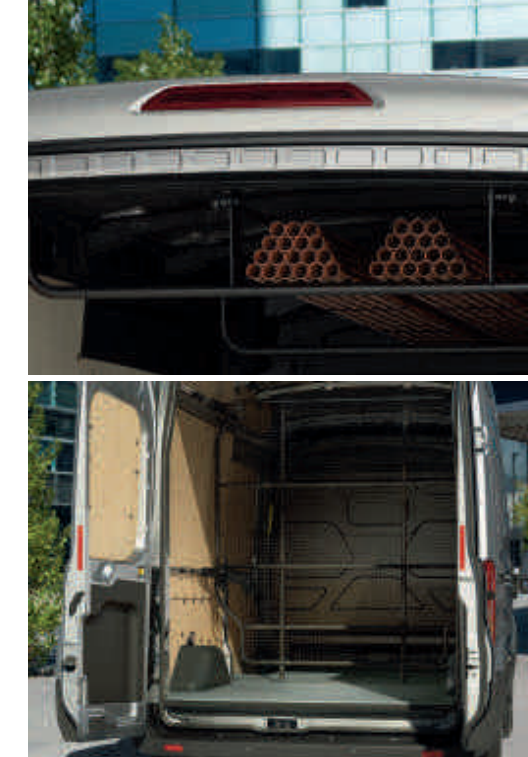

Loadspace divider

Black metal mesh bulkhead can be fitted in various positions to the Cargo side rails, to extend the versatility of your loadspace and form a secure load box. Loadspace divider is only available in combination with optional Cargo side rails (Accessory)

ClimAir** wind deflectors

Reduce wind turbulence and noise, allowing you a more enjoyable drive with the front windows down, even during light rain. (Accessory)

16" alloy wheels

16" alloy 5x2-spoke alloy wheels in Sparkle Silver. (Option and accessory)

Locking wheel nuts

Set of four locking wheel nuts to help protect wheels against theft. (Accessory, standard when alloy wheels are specified)

Brink** tow bar

For extra transport capability, the fixed tow bar can tow up to 3,500 kg, depending on engine. (Accessory) (Commercial users may need a digital tachograph).

For more accessories for your Ford Transit visit www.ford-accessories.co.uk

For a range of Ford branded items – from clothing to lifestyle products and model cars – visit www.fordlifestylecollection.com

Note: 180° rear cargo door hinge design appearance to change in Q3 2017.

+ Item covered by third party supplier's warranty, please see back cover for details.

	Availability	Part Number (FINIS)
Rear ladder, medium roof	A	1932621
Rear ladder, high roof	A	1932622
Rear window protection grille	A	1838135
Brink®+ tow bar, fixed	A	1855715
Brink®+ electrical kit for tow bar 13-pin connector	A	2051508
ClimAir** wind deflectors, front, light grey	A	1856560
ClimAir** wind deflectors, front, dark grey	A	1856561
Bosch** reverse warning device	A	1713304
Xvision+ Parking Distance Sensor(s), front	A	1804069
Xvision+ Parking Distance Sensor(s), rear	A	1804063
16" 5x2-spoke alloy wheel	A	1842987
Locking wheel nuts, set of 4	A	1763879
Rubber floor mats (single passenger seat)	A	2047028
Rubber floor mats (dual passenger seat)	A	2047030
Interior roof rack	A	1877186

A = Dealer fitted accessory, at extra cost, +Please see back cover for warranty information.

Bosch** reverse warning device

Linked to reverse gear. Provides an audible warning when the vehicle is reversing. (Accessory)



allsafe JUNGFALK** load retention pack and Delgnit** load floor kit

Load retention pack comprising half-height and full-height side rails with fixing kit, including fittings, hooks and lashing straps. Load floor kit includes hardwood floor with anti-slip coating and integrated airline rails (500 daN/ISO compliant). (Accessory)

allsafe JUNGFALK**

Secure complex loads safely and easily with lightweight cargo net systems, ideal for courier and parcel delivery services. (Accessory)



Electronic Stability Control

Ford Transit is fitted with Electronic Stability Control (ESC)⁽¹⁾ as standard. The advanced system constantly monitors the path the vehicle is following and compares it to the driver's intended course. If ESC senses a significant difference, it automatically reduces engine torque and applies brakes to individual wheels to help stabilise the vehicle and keep it safely on track.

Side Wind Stabilisation⁽²⁾

Helps the driver to stay in lane in strong, gusty conditions by using the ESC system to sense when the vehicle is being affected by crosswinds.

Curve Control⁽³⁾

Designed to sense when a driver takes a curve too quickly, and can rapidly reduce engine torque – and apply brakes to individual wheels – to help keep the vehicle safely under control. (Standard)

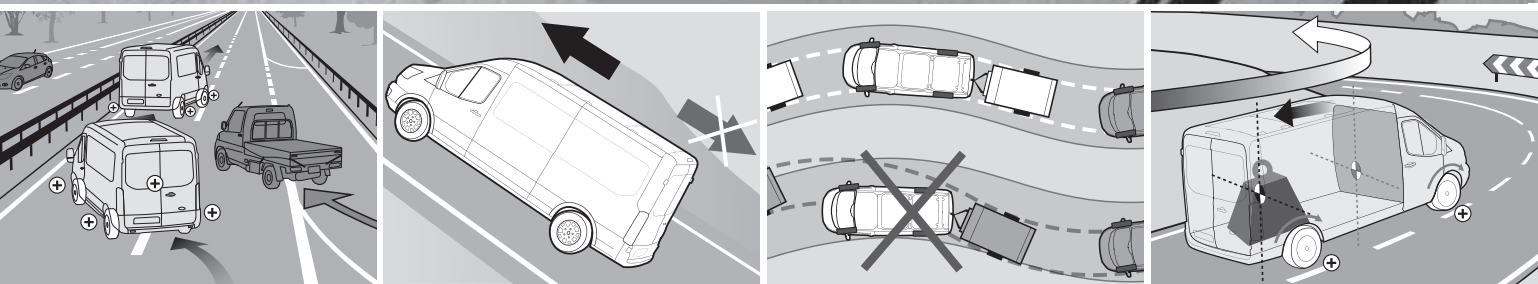
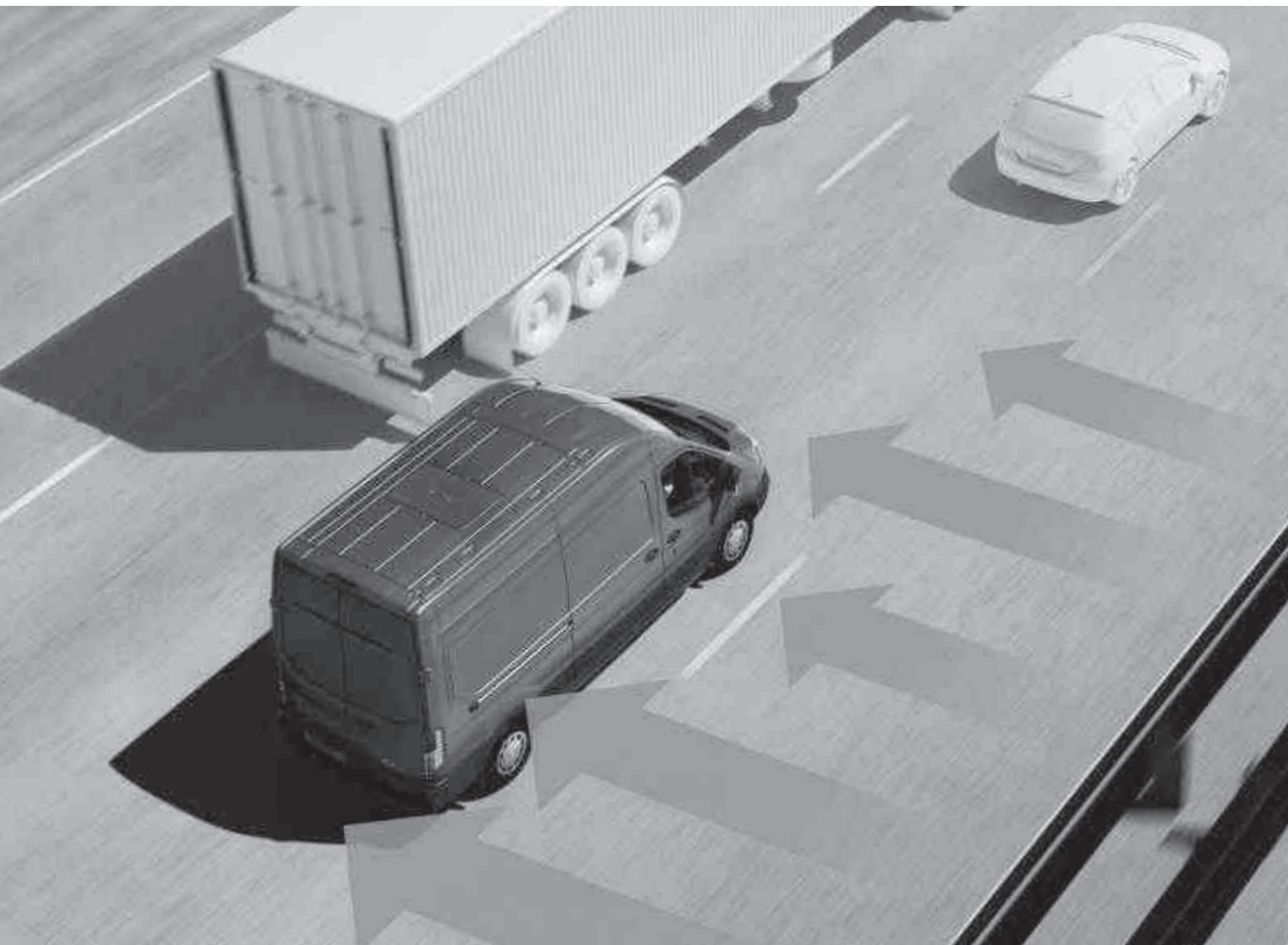

Roll Stability Control⁽¹⁾

Ford's unique roll-rate sensor helps the Roll Stability Control system to keep the tyres grounded under conditions of high centre of gravity and when driving through off-camber turns. (Standard)

Hill Start Assist⁽²⁾

Designed to temporarily prevent you from rolling down a slope when you move your foot from the brake pedal to the accelerator pedal. It works in forward and reverse gears, so is ideal for towing and pulling heavy loads. (Standard)

Trailer Sway Control⁽³⁾

When it detects trailer sway, the system is designed to reduce engine torque and apply the brakes to the appropriate wheel(s) to help maintain control – (standard but activated with optional with optional Ford trailer tow attachment.

Load Adaptive Control⁽³⁾

Designed to adjust the responses of the ESC⁽¹⁾ system to compensate when the vehicle is unladen, partially- or fully-laden. (Standard)

Get the most from your new Ford

We want to help you get the most from your new Ford. And to do that, you need to know how much it is designed to safely carry, both in terms of payload and load volume.

Your Ford Commercial Vehicle Dealer can provide professional advice on important specification aspects, and help to find the right van for your budget and business needs.

The Ford Transit is designed to carry cargo – and lots of it.

Choosing a new van is an important decision with lots of factors to be considered. While some aspects, like selecting the most appropriate derivative, identifying the intended primary use and determining load box size are relatively simple, others, such as calculating payload are more complex.

Payload capacity

To calculate payload, you need to know two things: the vehicle's gross vehicle mass (GVM) and its kerb mass.

GVM is the maximum permissible weight of the vehicle when loaded and ready to go – that includes the weight of the vehicle itself, ancillaries, driver and crew (assuming the industry standard weight of 75 kg/person), fluids, fuel tank 90% full (1 litre of diesel = approximately 0.85 kg), optional and aftermarket equipment, and cargo.

For simplicity, Ford Transit models are designated according to their GVM. For example, a 330 has a GVM of c. 3,300 kg; and a 350 has a GVM of c. 3,500 kg.

Kerb mass is the weight of a standard-specification Base series vehicle, including fluids and fuel tank 90% full, but without the driver, crew or cargo. **Payload** is the difference between the two.

Gross vehicle mass minus kerb mass = payload

So to help you choose the right vehicle for your needs, here are some more detailed explanations about the factors that can influence a vehicle's payload. These include, but are not limited to:

Driver and crew

We calculate the weight of the driver and crew based on the industry-standard weight of 75 kg/person. Remember that the driver and crew are not included in the kerb mass figure, so when a driver or crew boards the vehicle, its payload will be reduced accordingly.

Factory-fitted options

Most factory-fitted options will affect a vehicle's payload. For example, air conditioning can add approximately 18 kg to a vehicle's weight, and therefore reduce its payload accordingly.

However, specifying a single front passenger seat in lieu of the standard dual seat will reduce the vehicle's weight by approximately 12 kg, and increase its payload by the same amount. Your Ford Commercial Vehicle Dealer will be able to tell you what features can add or reduce your vehicle's kerb mass and by how much.

Series

All kerb masses quoted in this brochure are for standard-specification Base series models. Trend series models will generally weigh more than Base series due to the increased level of features and equipment.

Manufacturing tolerances

Variations in manufacturing and production processes mean that no two vehicles are likely to weigh exactly the same. For customers intending to load vehicles close to the maximum payload, we suggest you also add a margin for error of 5% of Kerb Mass to the Kerb Mass figure before calculation, to reduce the risk of overloading.

Accessories and aftermarket conversions

It is important to think carefully about what to do with your vehicle after you take delivery. Any accessories fitted or aftermarket conversions to the vehicle may adversely affect its payload. Please speak to your Ford Commercial Vehicle Dealer for more information and advice.

If payload is critical to your business, or if you plan to carry cargo at, or close to, the vehicle's maximum capacity, your Transit Centre can help.

Using their specialist expertise and knowledge, they can advise you on the exact specification of vehicle required to meet your individual business needs.

Note: Technical information for vehicle converters can be found online via the Body and Equipment Mounting Manual at www.etis.ford.com ; go to >information >>vehicle conversions.

Configure your van to suit your job

Ford Commercial Vehicles are available with a wide range of standard and optional features. Your Ford Transit Centre can help you ensure that you specify the right vehicle features for your specific business needs, including technical items to aid aftermarket fitment of specialist equipment or conversion.

⁽¹⁾Uses sensors.

⁽²⁾Safety feature.

⁽³⁾Driver assistance feature.

Note: 180° rear cargo door hinge design appearance to change in Q3 2017.

Weights, loads and performance

	Max. gross payload (excluding driver) (kg)	Gross vehicle mass (kg)	Min. kerb mass (excluding driver) (kg)	Front axle plated mass/with HD front axle (kg)	Rear axle plated mass (kg)
Van					
FWD					
290 L2 H2	914	2900	2026	1625	1575
310 L2 H2	1114	3140	2026	1650	1725
310 L2 H2 Automatic	1061	3140	2079	1650	1725
310 L3 H2	1034	3140	2106	1750	1725
330 L2 H2	1311	3365	2054	1750	2050
330 L3 H2	1231	3365	2134	1750	2050
350 L2 H2	1446	3500	2054	1750	2150
350 L2 H2 Automatic	1393	3500	2107	1750	2150
350 L3 H2	1366	3500	2134	1750	2250
350 L3 H2 Automatic	1313	3500	2187	1750	2250
RWD					
350 L2 H2	1319	3500	2181	1750/1850	2150
350 L3 H2	1256	3500	2244	1750/1850	2250
350 L4 H3	1111	3500	2389	1750/1850	2250
350 L4 H3 HD	969	3500	2531	1850	2450
470 L4 H3	2169	4700	2531	1850	3300
AWD					
350 L2 H2	1216	3500	2284	1850	2150
350 L3 H2	1153	3500	2347	1850	2250
Double Cab-in-Van					
FWD					
350 L2 H2	1289	3500	2211	1750	2250
350 L3 H2	1205	3500	2295	1750	2250
350 L3 H2 Automatic	1152	3500	2348	1750	2250
RWD					
350 L2 H2	1159	3500	2341	1750/1850	2150
350 L3 H2	1095	3500	2405	1750/1850	2250
350 L4 H3	947	3500	2553	1750/1850	2250
AWD					
350 L2 H2	1059	3500	2441	1850	2150
350 L3 H2	992	3500	2508	1850	2250

FWD = Front-wheel drive, **RWD** = Rear-wheel drive, **AWD** = All-wheel drive, **L2** = Medium wheelbase, **L3** = Long wheelbase, **L4** = Long wheelbase extended length, **H2** = Medium Roof, **H3** = High Roof. Figures apply to Medium Roof vehicles unless otherwise stated. For High Roof option vehicles, kerb mass is increased and payload reduced. Kerb mass is affected by many factors such as bodystyles, engines and options. It is the weight of a standard-specification base series vehicle (different series will have different kerb masses), including fluids and fuel tank 90% full, but without the driver 75 (kg), crew or cargo. Payload within this guide is the difference between gross vehicle mass (GVM) and kerb mass with a further 75 kg deduction for the weight of the driver. It must be noted that actual weight will always be subject to manufacturing tolerances which may result in payload variations between this guide and actual weight. For customers intending to load vehicle close to maximum payload, we suggest you also add a margin for error of 5% of Kerb Mass to the Kerb Mass figure before calculation, to reduce risk of overloading. NB: It is the responsibility of the vehicle operator to ensure their vehicles are legally compliant for road use. Consult your Ford Transit Centre for more information.

A smooth driving experience

SelectShift automatic transmission

For greater comfort and convenience in urban driving, Transit front-wheel drive derivatives can be specified with a six-speed SelectShift automatic transmission. Offering smooth, responsive and efficient performance, the transmission also provides the option of manual shifting using buttons on the gear lever. (Option on front-wheel drive models)

Max GTM

Van/Double Cab-in-Van	Axle ratio ^a	Standard/Optional	GVM				
			290	310	330	350	470
FWD							
2.0 TDCi Ford EcoBlue 105 PS (77 kW)	3.94/4.19	● / ○	4400/4940	4400/4940	-	-	-
2.0 TDCi Ford EcoBlue 105 PS (77 kW)	4.71	●	-	-	5100	5100	-
2.0 TDCi Ford EcoBlue (130 PS (96 kW)) 6-speed automatic	3.65	●	-	4100	-	4250	-
2.0 TDCi Ford EcoBlue 130 PS (96 kW)	3.94/4.19	● / ○	4840/4940	4840/4940	-	-	-
2.0 TDCi Ford EcoBlue 130 PS (96 kW)	4.43/4.71	● / ○	-	-	5050/5500	5050/5500	-
2.0 TDCi Ford EcoBlue (170 PS (125 kW)) 6-speed automatic	3.65	●	-	-	-	4250	-
2.0 TDCi Ford EcoBlue 170 PS (125 kW)	4.71/4.93	●	-	-	-	5500/6000	-
RWD							
2.0 TDCi Ford EcoBlue 105 PS (77 kW)	3.31	●	-	-	-	5500	-
2.0 TDCi Ford EcoBlue 130 PS (96 kW)	3.15/3.55	● / ○	-	-	-	5500/6000*	-
2.0 TDCi Ford EcoBlue 130 PS (96 kW)	4.10	●	-	-	-	-	6000*
2.0 TDCi Ford EcoBlue 170 PS (125 kW)	3.15/3.55	● / ○	-	-	-	5500/6300*	-
2.0 TDCi Ford EcoBlue 170 PS (125 kW)	4.10	●	-	-	-	-	7000*
AWD							
2.0 TDCi Ford EcoBlue (130 PS (96 kW)/170 PS (125 kW))	4.10	●	-	-	-	6000	-

● = Standard, ○ = Option, at extra cost. **Note:** All engines are Stage VI and include coated Diesel Particulate Filter (cDPF). ^aThe illustrated axle ratio shown is the one available dependent upon model, GVM payload and engine combination. *GTM is limited to 5500 kg if fitted with rear air conditioning. Consult your Transit Centre for more information.

Max. braked trailer plate (kg) **

Van/Double Cab-in-Van	Axle ratio ^a		290	310	330	350	470	350 DCIV
FWD								
2.0 TDCi Ford EcoBlue 105 PS (77 kW) (L2/L3)	3.94	●	2100/-	2100/2050	-/-	-/-	-/-	-/-
2.0 TDCi Ford EcoBlue 105 PS (77 kW) (L2/L3)	4.19	○	2650/-	2650/2600	-/-	-/-	-/-	-/-
2.0 TDCi Ford EcoBlue 105 PS (77 kW) (L2/L3)	4.71	●	-/-	-/-	2800/2700	2800/2700	-/-	-/-
2.0 TDCi Ford EcoBlue 130 PS (96 kW) 6-speed automatic (L2/L3)	3.65	●	-/-	1800/-	-/-	1900/1800	-/-	-/1650
2.0 TDCi Ford EcoBlue 130 PS (96 kW) (L2/L3)	3.94	●	2550/-	2550/2500	-/-	-/-	-/-	-/-
2.0 TDCi Ford EcoBlue 130 PS (96 kW) (L2/L3)	4.19	○	2650/-	2650/2600	-/-	-/-	-/-	-/-
2.0 TDCi Ford EcoBlue 130 PS (96 kW) (L2/L3)	4.43	●	-/-	-/-	2750/2650	2750/2650	-/-	-/-
2.0 TDCi Ford EcoBlue 130 PS (96 kW)	4.71	○	-	-	2800	2800	-	2800
2.0 TDCi Ford EcoBlue 170 PS (125 kW) 6-speed automatic (L2/L3)	3.65	●	-/-	-/-	-/-	1800	-/-	1650
2.0 TDCi Ford EcoBlue 170 PS (125 kW)	4.19/4.71/4.93	●	2800/-/-	2800/-/-	-/2800/-	-/2800/2800	-/-/-	-/2800/2800
RWD								
2.0 TDCi Ford EcoBlue 105 PS (77 kW)	3.31/3.73	● / ○	-	-	-	2800	-	2800
2.0 TDCi Ford EcoBlue 130 PS (96 kW)	3.15	●	-	-	-	2800	-	2800/2750***
2.0 TDCi Ford EcoBlue 130 PS (96 kW) (L3/L4)	3.55	○	-	-	-	2800	-	2800
2.0 TDCi Ford EcoBlue 130 PS (96 kW)	4.10	●	-	-	-	2800	2300	-
2.0 TDCi Ford EcoBlue 170 PS (125 kW)	3.15/3.55	● / ○	-	-	-	2800	-	-
2.0 TDCi Ford EcoBlue 170 PS (125 kW)	4.10	●	-	-	-	3500	3500	-
AWD								
2.0 TDCi Ford EcoBlue 130 PS (96 kW)/170 PS (125 kW)	4.10	●	-	-	-	2800	-	2800

● = Standard, ○ = Option, at extra cost. **Note:** All engines are Stage VI unless stated and include coated Diesel Particulate Filter (cDPF). ^aThe illustrated axle ratio shown is the one available dependent upon model, GVM payload and engine combination. Maximum unbraked trailer mass is 750 kg.***L4 DCIV. ** Max trailer weight will need to be reduced if maximum payload is to be achieved so as not to exceed maximum GTM.

The drive for cleaner air

Driving with AdBlue®

To operate correctly, the AdBlue® tank of your Ford Transit EcoBlue diesel engine must be filled with AdBlue® fluid. System warnings illuminate when the fluid level becomes too low. For more information, please discuss with your Ford Dealer.

Ford Easy-Fuel capless refuelling system

A unique safeguard ensures nobody can accidentally fill up with the wrong fuel. Plus no dirty fuel caps to touch. (Standard)

Van and Double Cab-in-Van dimensions

	L2 H2 Van		L2 H3 Van		L3 H2 Van		L3 H3 Van		L4 H3 Van
	FWD	RWD/AWD	FWD	RWD/AWD	FWD	RWD/AWD	FWD	RWD/AWD	RWD
A Overall length	5531	5531	5531	5531	5981	5981	5981	5981	6704
B Overall width with mirrors	2474	2474	2474	2474	2474	2474	2474	2474	2474
Overall width with folded back mirrors	2112	2112	2112	2112	2112	2112	2112	2112	2112
Overall width without mirrors (SRW)	2059	2059	2059	2059	2059	2059	2059	2059	2025
Overall width without mirrors (DRW)	-	-	-	-	-	-	-	-	2126
C Overall height*	2426-2490	2450-2542	2665-2781	2689-2781	2431-2541	2462-2543	2670-2780	2701-2782	2687-2790
D Wheelbase	3300	3300	3300	3300	3750	3750	3750	3750	3750
E Front of vehicle to front wheel centre	1023	1023	1023	1023	1023	1023	1023	1023	1023
F Rear of vehicle to rear wheel centre	1208	1208	1208	1208	1208	1208	1208	1208	1931
G Side door entry width	1300	1300	1300	1300	1300	1300	1300	1300	1300
H Side load door entry height	1700	1600	1700	1600	1700	1600	1700	1600	1600
I Rear door/tailgate entry width	1565	1565	1565	1565	1565	1565	1565	1565	1565
J Rear door/tailgate entry height	1748	1648	1987	1887	1748	1648	1987	1887	1887
K Maximum loadspace length (at floor with bulkhead)	2946**	2995**	3044	3044	3494	3494	3494	3494	4217
Maximum loadspace length (at 1.2m height with bulkhead)	2900	2900	2900	2900	3350	3350	3350	3350	4073
L Maximum loadspace width	1784	1784	1784	1784	1784	1784	1784	1784	1784
M Loadspace between wheel arches (SRW)	1392	1392	1392	1392	1392	1392	1392	1392	1392
Loadspace between wheel arches (DRW)	-	-	-	-	-	-	-	-	1154
N Load floor to roof	1886	1786	2125	2025	1886	1786	2125	2025	2025
O Loading height*	496-614	620-713	496-614	620-713	501-613	632-715	501-613	632-715	617-722
P Maximum load volume (with bulkhead) (cu.m)	10.0	9.5	11.2	10.7	11.5	11.0	13.0	12.4	15.1
Loadspace (with bulkhead) (VDA) (cu.m)	9.3	8.8	10.3	9.9	10.8	10.2	12.0	11.5	14.1
Double Cab-in-Van unique measurements									
G Side door entry width	1200	1200	1200	1200	1200	1200	1200	1200	1200
P Maximum load volume (with bulkhead) (cu.m)	6.1	5.7	6.7	6.4	7.6	7.2	8.4	8.0	10.6
Loadspace (with bulkhead) (VDA) (cu.m)	5.5	5.3	6.0	5.7	7.0	6.6	7.6	7.3	9.8
Q Maximum Loadspace Length	2038	2038	2038	2038	2488	2488	2488	2488	3211
R Useable load length at 1.2m height	1777	1777	1777	1777	2227	2227	2227	2227	2950
Turning circle (m)									
Kerb to kerb	11.9	11.9	11.9	11.9	13.3	13.3	13.3	13.3	13.3

L2 = Medium wheelbase, L3 = Long wheelbase, L4 = Long wheelbase extended length, H2 = Medium Roof, H3 = High Roof, FWD = Front wheel drive, RWD = Rear wheel drive, AWD = All wheel drive, SRW = Single rear wheels, DRW = Dual rear wheels. All dimensions (shown in mm) are subject to manufacturing tolerances and refer to minimum specification models and do not include additional equipment. *Height dimensions show the range from minimum to maximum of a fully laden, lowest payload vehicle to unladen highest payload vehicle. These illustrations are for guidance only. **Measurement taken with load floor liner fitted (option on Base, standard on Trend). **VDA method** This is the method used by the Verband der Automobilindustrie (VDA) in Germany. A VDA figure is determined by filling the loadspace with 'litre' blocks, each measuring 200x100x50 mm. The blocks are then counted, and the numerical result is converted into cubic metres.

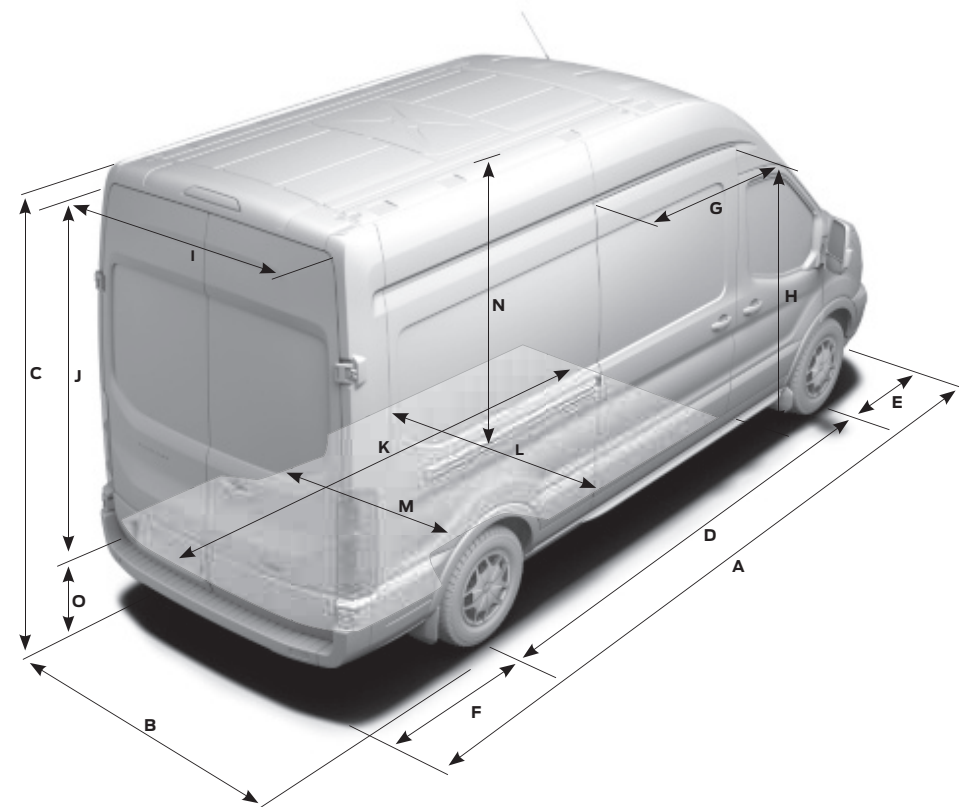

Model availability

	290 L2 H2	290 L2 H3	310 L2 H2	310 L2 H3	310 L3 H2	310 L3 H3	330 L2 H2	330 L2 H3	330 L3 H2	330 L3 H3	350 L2 H2	350 L2 H3	350 L3 H2	350 L3 H3	350 L4 H3	350 HDL4 H3	470 L4 H3
Van																	
FWD																	
2.0 TDCi Ford EcoBlue 105 PS (77 kW)	●	●	●	●	●	●	●	●	●	●	●	●	●	●	-	-	-
2.0 TDCi Ford EcoBlue 130 PS (96 kW)	●	●	●	●	●	●	●	●	●	●	●	●	●	●	-	-	-
2.0 TDCi Ford EcoBlue 130 PS (96 kW) 6-speed automatic	-	-	●	●	-	-	-	-	-	-	●	●	●	●	-	-	-
2.0 TDCi Ford EcoBlue 170 PS (125 kW)	-	-	-	-	-	-	-	-	-	-	●	●	●	●	-	-	-
2.0 TDCi Ford EcoBlue 170 PS (125 kW) 6-speed automatic	-	-	-	-	-	-	-	-	-	-	-	-	●	●	-	-	-
RWD																	
2.0 TDCi Ford EcoBlue 105 PS (77 kW)	-	-	-	-	-	-	-	-	-	-	●	●	●	●	●	-	-
2.0 TDCi Ford EcoBlue 130 PS (96 kW)	-	-	-	-	-	-	-	-	-	-	●	●	●	●	●	●	●
2.0 TDCi Ford EcoBlue 170 PS (125 kW)	-	-	-	-	-	-	-	-	-	-	●	●	●	●	●	●	●
AWD																	
2.0 TDCi Ford EcoBlue 130 PS (96 kW)	-	-	-	-	-	-	-	-	-	-	●	●	●	●	-	-	-
2.0 TDCi Ford EcoBlue 170 PS (125 kW)	-	-	-	-	-	-	-	-	-	-	●	●	●	●	-	-	-
Double Cab-in-Van																	
FWD																	
2.0 TDCi Ford EcoBlue 130 PS (96 kW)	-	-	-	-	-	-	-	-	-	-	●	●	●	●	-	-	-
2.0 TDCi Ford EcoBlue 130 PS (96 kW) 6-speed automatic	-	-	-	-	-	-	-	-	-	-	-	-	●	●	-	-	-
2.0 TDCi Ford EcoBlue 170 PS (125 kW)	-	-	-	-	-	-	-	-	-	-	-	-	●	●	-	-	-
2.0 TDCi Ford EcoBlue 170 PS (125 kW) 6-speed automatic	-	-	-	-	-	-	-	-	-	-	-	-	●	●	-	-	-
RWD																	
2.0 TDCi Ford EcoBlue 105 PS (77 kW)	-	-	-	-	-	-	-	-	-	-	●	●	-	-	-	-	-
2.0 TDCi Ford EcoBlue 130 PS (96 kW)	-	-	-	-	-	-	-	-	-	-	●	●	●	●	●	-	-
2.0 TDCi Ford EcoBlue 170 PS (125 kW)	-	-	-	-	-	-	-	-	-	-	●	●	●	●	-	-	-
AWD																	
2.0 TDCi Ford EcoBlue 130 PS (96 kW)	-	-	-	-	-	-	-	-	-	-	●	●	●	●	-	-	-

● = Available, - = Not available. L2 = Medium wheelbase, L3 = Long wheelbase, L4 = Long wheelbase extended length, H2 = Medium Roof, H3 = High Roof, FWD = Front-wheel drive, RWD = Rear-wheel drive, AWD = All-wheel drive. All engines are Stage VI with 6-speed manual transmission unless stated.

Van

10.0*/9.3** cu.m (FWD), 9.5*/8.3** (RWD/AWD)	11.5*/10.8** cu.m (FWD), 11.0*/10.2** (RWD/AWD)	
11.2*/10.3** cu.m (FWD), 10.7*/9.9** (RWD/AWD)	13.0*/12.0** cu.m (FWD), 12.4*/11.5** (RWD/AWD)	15.1*/14.1** cu.m
Double Cab-in-Van		
6.1*/5.5** cu.m (FWD), 5.7*/5.3** (RWD/AWD)	7.6*/7.0** cu.m (FWD), 7.2*/6.6** (RWD/AWD)	
6.7*/6.0** cu.m (FWD), 6.4*/5.7** (RWD/AWD)	8.4*/7.6** cu.m (FWD), 8.0*/7.3** (RWD/AWD)	10.6*/9.8** cu.m

*Maximum load volume (with bulkhead), **Loadspace (with bulkhead) (VDA)

Note: 180° rear cargo door hinge design appearance to change in Q3 2017.

Fuel Economy and Emissions

The fuel economy figures quoted in the table below are achieved by following strict EU governed test procedures and are specifically designed to enable customers to compare vehicles from all manufacturers on a like-for-like basis. Fuel consumption is directly affected by the length of the journey; number of passengers and amount of luggage carried; individual driving style; road and traffic conditions; weather conditions; vehicle age, mileage, condition and standard of maintenance; use of vehicle features such as air conditioning; and any modifications to the vehicle such as the addition of a roof rack. Your fuel economy will vary based on these and other factors and, for these reasons, many drivers may not achieve the EU fuel economy figures (below) in day-to-day driving, although the vehicle is technically capable of doing so.

Van/Double Cab-in-Van	Axle ratio/ Optional towing axle ⁶	CO ₂ emissions (g/km) ⁶	Fuel consumption L/100 km ⁶			Fuel consumption mpg ⁶		
			Urban	Extra Urban	Combined	Urban	Extra Urban	Combined
FWD								
2.0 TDCi Ford EcoBlue 105 PS (77 kW)/130 PS (96 kW) (290 & 310 series)	3.94/4.19	174-177	7.0	6.4-6.6	6.7	40.4	44.1-42.8	42.2
2.0 TDCi Ford EcoBlue 105 PS (77 kW)/130 PS (96 kW)/170 PS (125 kW) (330 & 350 series)	4.71	179-184	7.6-7.7	6.6-6.9	6.9-7.1	37.2-36.7	42.8-40.9	40.9-39.8
2.0 TDCi Ford EcoBlue 130 PS (96 kW), 6-speed automatic (310 series)	3.65	190-194	7.8-7.9	7.0-7.1	7.3-7.5	36.2-35.8	40.4-39.8	38.7-37.7
2.0 TDCi Ford EcoBlue 130 PS (96 kW), 6-speed automatic (350 series)	3.65	190-197	7.8-8.0	7.0-7.2	7.3-7.6	36.2-35.3	40.4-39.2	38.7-37.2
2.0 TDCi Ford EcoBlue 130 PS (96 kW) (350 series)	4.43/4.71	176-184	7.1-7.7	6.6-6.9	6.8-7.1	39.8-36.7	42.8-40.9	41.5-39.8
2.0 TDCi Ford EcoBlue 170 PS (96 kW) (350 series)	4.93	185-192	7.9-8.0	6.8-7.1	7.1-7.4	35.8-35.3	41.5-39.8	39.8-38.2
2.0 TDCi Ford EcoBlue 170 PS (125 kW), 6-speed automatic (350 series)	3.65	194-197	7.9-8.0	7.1-7.2	7.5-7.6	35.8-35.3	39.8-39.2	37.7-37.2
RWD								
2.0 TDCi Ford EcoBlue 105 PS (77 kW) (350 series)	3.31/3.73	189-202	8.3-8.8	6.8-7.1	7.3-7.7	34.0-32.1	41.5-39.8	38.7-36.7
2.0 TDCi Ford EcoBlue 130 PS (96 kW)/170 PS (125 kW) (350 series)	3.15/3.55	185-200	8.0-8.7	6.6-7.1	7.1-7.7	35.3-32.5	42.8-39.8	39.8-36.7
2.0 TDCi Ford EcoBlue 130 PS (96 kW)/170 PS (125 kW) (350HD & 470 series)	4.10	212	9.1	7.5	8.2	31.0	37.7	34.5
AWD								
2.0 TDCi Ford EcoBlue 130 PS (96 kW)/170 PS (125 kW)	4.10	226	10.2	7.8	8.7	27.7	36.2	32.5

Note: Values are shown with Auto-Start-Stop where possible. Auto-Start-Stop system reduces CO₂ emissions and fuel consumption by 6 g/km and between 0.2 and 0.4 L/100km. ⁶The illustrated axle ratio shown is the one available dependent upon model, GVM payload and engine/transmission combination. ⁶The declared fuel consumptions and CO₂ emissions for Stage VI HDT engines are measured according to the technical requirements and specifications of the European Directive 80/1268/EEC and ECE R101.01. The declared fuel consumption and CO₂ emissions for Stage 6 LDTIII engines are measured according to the technical requirements and specifications of European Regulation (EC) 715/2007 and latest amendment. Fuel consumption and CO₂ emissions are specified for a vehicle variant and not for a single car. The applied standard test procedure enables a comparison between different vehicle types and different manufacturers and assumes a driver (75kg), 90% of fuel and AdBlue[®] plus 25kg. In addition, the specification and options selected may have an effect i.e. on vehicle weight and therefore on the emissions and fuel economy of the vehicle and also may influence the figures that appear in the individual vehicle documentation. This information is not part of any product offer made. Real world fuel consumption can vary as the fuel efficiency of a vehicle is influenced by (individual) vehicle configurations, driving behaviour, use of technical equipment such as air conditioning well as other non-technical factors. Consult your Dealer for more information.

Exterior features

	Base	Trend		Base	Trend
Design features					
Body – H2 (Medium Roof; not available on L4)	●	●	Door handles – Self colour	●	●
Body – H3 (High Roof; standard on L4)	○/●	○/●	Cargo door handle – Self colour	●	●
Door mirrors – Blind spot eliminator and integrated side indicator	●	●	Front grille – Sterling Grey	●	–
Door mirrors – Manual adjust	●	–	Front grille – Titanium effect	–	●
Door mirrors – Electrically-operated and heated	○/□	●	Rear privacy glass (Standard on DCIV Trend, optional on Van) (43% light transmittance)	○	○/●
Door mirrors – Power-foldable, electrically-operated and heated	○	●	Tinted glass – Complete (optional on DCIV Trend) (72% light transmittance - side windows)	●	●/○
Bodyside mouldings – Wide, self colour	●	●	Mudflaps – Front	○	○
Front bumper – Self colour	●	●	Mudflaps – Rear	●	●
Rear bumper – Self colour with integrated step	●	●	Tow bar with Trailer Sway Control and 13-pin electrics (tachograph may be required) (not available on Double Cab-in-Van AWD 350 models)	○	○

● = Standard, ○ = Option, at extra cost, □ = Part of an option pack, at extra cost. **L2** = MWB, **L3** = LWB, **L4** = ELWB.

Parking distance sensors, front and rear²⁾

An audible warning helps you judge the distance between your vehicle and obstacles at the front and rear, for easier parking and manoeuvring. (Standard on Trend, option and accessory on Base)

¹⁾Uses sensors.

²⁾Driver assistance feature.

Note: 180° rear cargo door hinge design appearance to change in Q3 2017.

Exterior features

	Base	Trend
Wheels		
Steel – 15"x6½" (Fitted with 215/65 R15 BSW tyres; standard on 290 and 310 series only) (not available with Auto Transmission)	●	●
Steel – 16"x6½" (Fitted with 215/65 R16C tyres; 330 and 350 series, including with automatic transmission; 235/65 R16C 115/113 BSW tyres)	●	●
Steel – 16"x6", dual rear wheels, hub caps on front wheels (Fitted with 195/75 R16C BSW tyres; standard only on 470 series, and optional only on 350 L4 RWD series. Not available on AWD)	○	○
Alloy – 16"x6½", 5 spoke (Fitted with 215/65 R16C BSW tyres; 290 and 310 series; 215/65 R16C BSW tyres; 330 and 350 series; 235/65 R16C BSW 115/113 BSW tyres; includes locking wheel nuts)	–	○
Wheel covers – Half caps (SRW only)	●	–
Wheel covers – Full (SRW only)	–	●
Spare – Full-size steel with tool kit (standard with DRW on 350HD & 470 models)	○/●	○/●
Tyre inflator kit (not available with DRW on 350HD & 470 models)	●/–	●/–
Convenience features		
Headlights – Projector-style halogen reflector lights with black background	●	–
Headlights – Projector-style halogen reflector lights with chrome background and static cornering lights	–	●
Headlights – Daytime running lights	●	●
Headlights – Automatic on/off	□	●
Headlights – Courtesy delay, 30 seconds duration	●	●
Fog lights – Front	○	●
Doors – Driver's side load (sliding) door (not available on L4 DCIV)	○	○
Doors – Passenger's side load (sliding) door	●	●
Doors – Passenger's side load (sliding) door and power step (step not available on FWD and AWD)	○	○
Doors – Unglazed rear doors, hinged for 180° opening, positive stop at 90° (standard on L2 and L3, not available on L4)	●/–	●/–
Doors – Unglazed rear doors, hinged for widest opening (236°), with magnetic door retainers (not available on L2, optional on L3 and standard on L4)	–/○/●	–/○/●
Rear window – Fixed	○	○
Doors – Glazed and heated	○	○

	Base	Trend
Engine undershield	○	○
Roof marker lights (DRW Van models only)	●	●
Side marker lights (L4 models only)	●	●
Side windows – Second row, fixed (optional on Base only on Double Cab-in-Van)	○	○
Side windows, Van – Second row, passenger's side, fixed	○	○
Side windows, Double Cab-in-Van – Second row, sliding	●	●
Side windows, Double Cab-in-Van – Second row, fixed	○	–
Wipers – Front, variable/intermittent with electric wash	●	●
Wipers – Front, automatic with rain sensor (includes automatic headlights)	□	●
Wipers – Rear with auto reverse wipe and electric wash (only available with glazed rear doors)	○	○
Parking distance sensors – Front and rear (includes front fog lights)	○	●
Rear window ladder (only available with 180° hinged rear doors) (not available with L4 models)	○	○

Option packs

Low Visibility Pack – Quickclear heated windscreen, washer fluid sensor, and electrically-operated and heated door mirrors

Premium Visibility Pack – Lane-Keeping Alert (including Auto High Beam and Driver Alert), rear-view camera

● = Standard, ○ = Option, at extra cost, □ = Part of an option pack, at extra cost. **L2** = MWB, **L3** = LWB, **L4** = ELWB.

*The wheel you choose will be fitted with the tyre size noted, but no choice of tyre brand is available.



Braking system and all-wheel drive

Whatever the working environment, Transit makes driver and passenger protection its top priority. Standard safety features include ABS with Emergency Brake Assist (EBA) to help reduce emergency stopping distances. Larger brake pads and discs last longer and are more resistant to brake fade, while wear sensors indicate when pads are due for replacement. For more challenging conditions, Transit is available with all-wheel drive (AWD). This latest system automatically directs more drive to the front axle for optimum traction, and can also operate pre-emptively to avoid wheel slip by monitoring the driver's actions.

*All-wheel drive is available as an option on Van 350 L2/L3 and Double Cab-in-Van 350 L2/L3

Engineered for maximum traction

Tested to extremes

From frost-covered prototypes started up in -40°C at 4,500-metre altitudes, to sun-baked vehicles towing fully-laden trailers up long inclines in 50°C heat, Transit has been pushed to extremes.



Interior features

	Base	Trend
Design features		
Floor covering – Cab, easy-clean rubber (Van only)	●	●
Floor covering – Full length, easy-clean rubber (Double Cab-in-Van only)	●	●
Headlining – Cab, moulded (Van only)	●	●
Headlining – Extended, moulded (standard on Double Cab-in-Van only)	●	●
Steering wheel – 4-spoke, polyurethane	●	–
Steering wheel – 4-spoke, leather-trimmed (Standard on N2 variants as part of Lane Keeping Alert)	□	●
Interior lighting		
Courtesy lights – Header-mounted, front with theatre dimming	●	–
Courtesy lights – Header-mounted, front map lights	–	●
Courtesy lights – Rear seat, with theatre dimming (Double Cab-in-Van)	●	●
Courtesy lights – Footwell illumination (side load door only)	–	●
Loadspace compartment lights	●	●
Loadspace compartment lights – LED	○	○
Interior lighting/battery saver – 30 minutes	●	●
Audio and communication systems		
Delete audio system	○	–
My Connection Radio, Bluetooth® with USB/iPod® connectivity port and iPod® functionality, remote audio controls, four front speakers (two woofers and two tweeters) (ICE Pack 2)	●	–
Radio/CD with 4" TFT screen, Ford SYNC – including Emergency Assistance*, AppLink®, Bluetooth® with Voice Control System and audible text messaging, Privacy Mode, USB connectivity port with iPod® functionality, steering wheel mounted audio controls, four front speakers (two woofers and two tweeters) (ICE Pack 8)	○	●
DAB Radio/CD with 4" TFT screen, Ford SYNC – including Emergency Assistance*, AppLink®, Bluetooth® with Voice Control System and audible text messaging, Privacy Mode, USB connectivity port with iPod® functionality, steering wheel mounted audio controls, four front speakers (two woofers and two tweeters) (ICE Pack 9)	○	○
Radio navigation system, 6" TFT Touchscreen display, SYNC 3 with Navigation, Voice Control, Apple CarPlay, Android Auto, Emergency Assistance*, hands-free calling, GPS, Bluetooth® and Voice Control and audible text messaging, USB, Privacy Mode, remote audio controls and four speakers (two woofers and two tweeters) (ICE Pack 15)	○	○

Instruments and controls

	Base	Trend
Trip computer (distance to empty, instant and average fuel consumption, average speed, outside temperature)	●	●
Water in fuel filter with sensor	●	●
Heavy duty starter motor (-29°C)	○	○
Battery – Cold start (-20°C)	●	●
Battery – Single Improved Flooded (IF) (Front Wheel Drive)	●	●
Battery – Single H8 Absorbent Glass Mat (AGM) 95Ah 850CCA (Rear Wheel Drive)	●	●
Battery – Twin H8 Absorbent Glass Mat (AGM) 2x 95Ah 850CCA	○	○
Alternator – Standard duty (165 Amp)	●	●
Alternator – Extra heavy duty (240 Amp)	○	○
Auxiliary Connection Point – 1 X 12V, 60A connection located under driver seat pedestal	●	●
Auxiliary Connection Point – 3 X 12V, 60A connections located under driver seat pedestal	□	□
Tachograph – Digital, electronic, 24-hour (not available with automatic transmission)	○	○
Gear Shift Indicator	●	●

● = Standard, ○ = Option, at extra cost, □ = Part of an option pack, at extra cost.

*Ford Emergency Assistance operates in over 30 European countries. This feature works when paired with a compatible connected mobile phone that is with you when an airbag is deployed (excludes knee airbags and rear inflatable safety belts, if equipped) or the fuel pump shut off switch is activated. See your local Ford website for latest information. **Note:** The Bluetooth® word mark and logos are owned by the Bluetooth SIG, Inc. and any use of such marks by Ford Motor Company is under licence. Other trademarks and trade names are those of their respective owners.



Bluetooth® Audio Streaming

Stream your music collection from your mobile phone or other compatible device to the vehicle's audio system.

Navigation

3D map shows points of interest on Ford SYNC 3's 6" colour touch screen. Also includes traffic announcements. (Option)

Complete connectivity

Ford SYNC 3 lets you operate most popular Bluetooth®-enabled phones and USB drives with remarkably simple voice commands. (Option)

Emergency Assistance*

Innovative SYNC feature that uses a Bluetooth®-paired and connected mobile phone to help vehicle occupants initiate a direct call to the local Communications Centre (in more than 40 European countries and regions), following a vehicle crash event involving an airbag deployment or fuel pump shut off. (Option, part of Ford SYNC)

Rear-view camera with Trailer Hitch Assist

Select reverse gear and the image from the rear-view camera is displayed automatically in the Ford SYNC screen. Marker lines overlaid on the camera image indicate where the vehicle is heading. (Option when audio system with SYNC is specified)



Audible SMS

Have your incoming text messages read to you from your connected phone, including commonly-used abbreviations and emoticons, and you can even respond with a choice of 15 preset text messages. Compatible mobile phone required. (Option, part of Ford SYNC)



*Compatible and connected mobile phone required. You can browse a list of AppLink-compatible apps from your regional Ford website, or via the **App Catalog** available in iOS and Android stores. SYNC AppLink and Emergency Assistance are not supported by all European languages.

Note The Bluetooth® word mark and logos are owned by the Bluetooth SIG, Inc. and any use of such marks by Ford Motor Company Limited and its associated companies is under licence. Other trademarks and trade names are those of their respective owners.

Interior features

	Base	Trend
Seats		
Driver's seat – 8-way (fore/aft; recline; height; and tilt) with armrest	●	–
Driver's seat – 10-way (fore/aft; recline; height; tilt; and lumbar) with armrest	○	●
Driver's seat – 10-way power adjustable heated (fore/aft; recline; height; tilt; and lumbar) with armrest	–	○
Front passenger's seat – Single, 8-way (fore/aft; height; tilt; and recline)	○	○
Front passenger's seat – Single, 8-way heated (fore/aft; height; tilt; and recline)	○	○
Front passenger's seat – Dual, fixed back with split lift-up seat cushion for stowage	●	●
Front passenger's seat – Dual, heated, fixed back with split lift-up seat cushion for stowage	○	○
Front passenger's seat – Dual, fixed back with split lift-up seat cushion for stowage, fold out table	●	●
Front passenger's seat – Dual, heated, fixed back with split lift-up seat cushion for stowage, fold out table	○	○
Rear seats, Double Cab-in-Van – Second row; removable triple wide seats (includes moulded bulkhead with window behind 2nd row seats)	●	●
Rear seats, Double Cab-in-Van – Second row; removable quad seats with underseat storage (L3 350 variant only)	○	○
Comfort and convenience		
Air conditioning – Front, including pollen filter	○	○
Rear air conditioning (includes front manual A/C, 230V 3 pin power point and HD Alternator) RWD/AWD Van only, cool air only	○	○
Heater – Positive Thermal Co-efficient (PTC)	●	●
Assist handle – Located on B-pillar	●	●
Bottle holder – Twin, 2-litre bottle capacity, facia-mounted	●	●
Glovebox – With lid and A4 file storage capability	●	–
Glovebox – Lockable, with lid and A4 file storage capability	–	●
Power point socket – 2 x 12 V (located on instrument panel and in stowage bin)	●	●
Power point – 230V (150W) power converter (requires single AGM battery on FWD models) (not available with SVO options A540 or A550)	○	○
Power point socket – 12V (located in rear) (requires single AGM battery on FWD models)	○	○
Smokers' Pack – Cigar lighter and ash cups	○	○

	Base	Trend
Storage – Front door map pockets	●	●
Storage – Driver's side, storage compartment on facia top with lift up lid	●	●
Storage – Underseat stowage compartment (under dual passenger seat)	●	●
Storage – Overhead stowage shelf	●	●
Windows – Electrically-operated front with one-touch down on driver's side	●	●
Rear-view camera (including Trailer Hitch Assist and front and rear parking sensors) (image in 4" TFT display or 6" TFT Touchscreen display (standalone option or part of pack) (requires ICE Pack 8, 9 or 15 at extra cost)	○/□	○/□
Load compartment		
Bulkhead – Delete (Vans only)	○	–
Bulkhead – Full width metal, unglazed (not Double Cab-in-Van)	●	●
Bulkhead – Full width metal with window (not Double Cab-in-Van) (requires glazed rear doors)	○	○
Bulkhead – Moulded with window (standard on Double Cab-in-Van)	●	●
Complete rear trim full-height board (only in Van)	○	○
Complete rear sidewall trim half-height board with wheelarch covers (standard on all DCIV)	○/●	●
Easy Clean Load Floor (not Double Cab-in-Van)	○	●
Load area protection kit – Complete rear trim full-height board, Easy To Clean Load Floor and load compartment tie-down loops (not available with rear compartment heater) (not Double Cab-in-Van)	○	○
Load compartment – DIN 75410 compliant tie-down loops, minimum of 8 (L2 Double Cab-in-Van = 6)	●	●
Load retention pack (Van only)	○	○
Loadspace divider (only available with flex floor) (Van only)	○	○
Flex floor (available on van only)	○	○
Interior roof rack (Van only with unglazed rear doors)	○	○

● = Standard, ○ = Option, at extra cost, □ = Part of an option pack, at extra cost.



Steering wheel-mounted controls

Allows you to operate the audio system and trip computer without taking your hands off the wheel. (Standard with Ford audio systems)



Quickclear heated windscreen

Clears ice or demists the windscreen quickly, even on frosty mornings for year-round comfort and visibility. (Option as part of Low Visibility pack on Base, Standard on Trend and 350HD and 470 models)

Lidded storage compartment with power point and USB port

Cleverly concealed storage compartment, located above the instrument cluster, features a 12-volt power supply and USB port. (Standard with Ford audio systems)

A place for everything

Transit's driver-focused cab combines modern good looks with smart stowage solutions. With plenty of space for bottles, phones and papers, it will help make your workday easier and more efficient.

Electrically-operated driver's seat

A 10-way electrically-adjustable heated driver's seat with lumbar support is an ideal choice for vehicles with multiple drivers. (Option)

Adjustable driver's seat and steering wheel

An adjustable driver's seat with armrest and a steering wheel that adjusts to suit your height and arm length mean you can find your ideal driving position with ease. (Standard)



Safety and security features

	Base	Trend
Safety and driver assistance		
Anti-lock braking system (ABS) with electronic brake-force distribution (EBD) ¹⁾	●	●
Electronic Stability Control (ESC) ¹⁾	●	●
Curve Control ¹⁾	●	●
Hill Start Assist (HSA) ²⁾	●	●
Load Adaptive Control (LAC) ¹⁾	●	●
Emergency Brake Assist (EBA) ¹⁾	●	●
Emergency Brake Warning ²⁾	●	●
Roll Stability Control (RSC) ¹⁾	●	●
Trailer Sway Control (TSC) ¹⁾ (activated with Ford trailer tow attachments)	○	○
Airbag – Driver's ¹⁾	●	●
Airbag – Front passenger's ⁴⁾ (includes passenger's airbag deactivation switch)	○	○
Airbag – Front side and curtain airbags ¹⁾	□	□
Lane-Keeping Alert ²⁾ (includes Driver Alert ²⁾ and Auto High Beam ¹⁾ , high series instrument cluster and heated windscreen) (Standard on 350HD and 470 series)	○	○/□
Cruise control (including leather-trimmed steering wheel and Adjustable Speed Limiter)	○	●
Adaptive Cruise Control (includes Pre-Collision Assist, Forward Alert and Traffic Sign Recognition) ²⁾	○	○
Seat belts – 3-point diagonal inertia reel (all seats) ¹⁾	●	●
Tyre Pressure Monitoring System (TPMS) ¹⁾ (not available with dual rear wheels)	○	○

	Base	Trend
Security		
Alarm – Perimeter	○	○
Alarm – Thatcham Category 1 – Cab interior sensing, inclination sensor and trailer coupling, when fitted (includes remote locking with 2 key fobs) (only available with full metal bulkhead and unglazed rear doors)	○	○
Doors – Unglazed rear	●	●
Immobiliser – Safeguard Passive Anti-Theft System (PATS) (Insurance-approved Category 2 Immobiliser)	●	●
Locks – Power central locking	○	–
Locks – Power door deadlocks, shielded with strengthened mountings	●	●
Locks – Remote control central locking with one key fob	●	–
Locks – Remote control central locking with two key fobs	○/□	●
Locks – Manual fleet key (Not available on DCiV Trend)	○	○/–
Locks – Configurable unlocking – 2-stage unlocking*	●	●
Locks – Configurable unlocking – independent driver's door unlocking*	○	–
Locks – Configurable unlocking – courier unlocking with auto slam lock, zonal opposite door relocking and 3 second auto relocking* (Van only)	○	–
Locks – Auto relocking, doors relock after 45 seconds if no door is opened	●	●
Locks – Audio mis-lock feedback, audible signal if a door is ajar when locking activated	●	●
Locks – Auto locking on drive-away, doors automatically lock at 5 mph (not Double Cab-in-Van)	●	●
Two-stage unlocking with slam locking	○	–
Locks – Key-operated bonnet release	●	●
Vehicle Identification Number – Visible	●	●

● = Standard, ○ = Option, at extra cost.

¹⁾Safety feature, ²⁾Driver assistance feature. □ = Part of an option pack, at extra cost. *For details of the configurations available please consult your Ford Transit Centre. Please note: Configurable locking must be defined at the time of order, it cannot be ordered as a Dealer-fitted option or accessory.

***Note: A rear-facing child seat should never be placed in the front passenger seat when the Ford vehicle is equipped with an operational front passenger's airbag.**

Mechanical features

	Base	Trend
Engine technology		
Auto-Start-Stop system (not available with AWD) (requires single AGM battery on FWD models)	○	○
Ford Eco Mode driver information system	●	●
Acceleration control	○	○
Coated diesel particulate filter (cDPF)	●	●
Brakes		
Dual-circuit, with self-adjusting servo-assistance and ABS. Front and rear discs	●	●
Fuel tank		
72 litres	●	●
Ford Easy-Fuel capless refuelling system with misfuel inhibit	●	●
Urea aftertreatment system – 21 litre	●	●
Steering		
Power-assisted steering (PAS)	●	●
Steering column – Rake- and reach-adjustable	●	●
Suspension		
Front, independent MacPherson struts, variable rate coil springs, stabiliser bar gas-pressurised shock absorbers and rear leaf springs	●	●
Engine governors		
Speed Limiter – 56mph (legal requirement on vehicles over 3.5 GVM) (standard on 470GVM models)	○/●	○/●
Speed Limiter – 62mph	○	○
Speed Limiter – 70mph	○	○

● = Standard, ○ = Option, at extra cost.

SVO

	SVO Code	Base/Trend
Body		
Omit passenger seat (Van only; no pedestal) (not available on DCiV)	A304	○
Hi-visibility Orange seat belts (available with single/dual/delete front passenger seat) (front row only on DCiV)	A305/6/7	○/–
Electrical		
Engine RPM speed control, 1300-3000 rpm (Manual Transmission only)	A003	○
Auxiliary fuse panel	A526	○
Beacon Preparation Pack – Switch and front and rear wiring (includes auxiliary fuse panel A526) (cannot be ordered with rear air conditioning)	A606	○
Utility Vehicle Switch Pack (Provides three switches for beacon and two power outputs; includes auxiliary fuse panel (A526) and Beacon Preparation Pack A606) (cannot be ordered with rear air conditioning)	A607	○
High Specification Interface Connector (Provides a range of hardwired signals and power; includes auxiliary fuse panel A526. Cannot be ordered with Utility Vehicle Switch Pack A607)	A608	○
Trailer tow electrics (connector and wiring) without the tow bar (Van only)	A055	○
The Ford Programmable Battery Guard – Patented 10-mode programmable battery guard system capable of protecting Ford and 3rd party battery	A540	○
Converter – High Power Supply System – Meets heavy power-take-off requirements by equipping vehicles with two high performance deep cycle AGM Batteries (2 x 95 Ah), 240A alternator, Engine RPM speed control and the Ford Programmable Battery Guard (Manual Transmission only)	A550	○
Other		
DPF Manual Regeneration	A660	○
Rear Air Conditioning (includes front manual A/C) (FWD models only) (Van only) (does not include cover for rear HVAC or ducting)	A813	○
Paint		
Special paint, 140 solid colours available, consult your Ford Transit Centre for details*	Various	○

○ = Option, at extra cost. *SVO paint suffix must be entered at time of ordering. SVO paint pulls self-colour (black) bumpers, bodyside mouldings, mirror housings and door handles.



Configurable unlocking

Transit's locking system is more secure than ever. That's because you can open one individual door without automatically unlocking the others. The other doors stay securely locked until you activate a switch on the driver's door. (Option on Base, not available on Trend)

Note: 180° rear cargo door hinge design appearance to change in Q3 2017.

Underseat stowage compartment

The front dual passenger seat cushions flip up to reveal a hidden compartment large enough to hold a toolbox. (Standard) The centre seat also incorporates a fold-down table, large enough to hold an A4 clipboard, tablet or a laptop computer. (Standard)



Making life easy

Our range of finance, service and assistance options is designed with just one thing in mind – making life easy for you.

Ford Transit24

At Ford we recognise the importance of minimising downtime, inconvenience and expense – that's why we provide first-class aftersales support.

When it comes to the service, maintenance and repair of your Ford commercial vehicles, look no further than your nearest Transit Centre. Dedicated to looking after your vehicle, Transit Centres offer specialised workshop equipment, tools and training, and can look after all your service, maintenance and warranty work.

Convenient servicing

While-you-wait servicing Your commercial vehicle can be serviced when it suits you. Late night service appointments are available at least once a week and we respond to link online service booking requests within twenty minutes.

Collection and delivery This can be arranged at the time of your service booking for locations within a reasonable travelling time. So that it looks its best, your vehicle will be washed.

MOTs and more Transit Centres can handle MOTs (including Class 5 and 7 tests), tachograph servicing and speed limiting (VOSA approved).

Other benefits

Ford parts availability Ford will endeavour to ensure any parts required will either be in stock or delivered anywhere on the UK mainland by 9am the next working day.

Genuine Ford parts quality All parts are designed and engineered by Ford, to Ford standards. Parts fitted to a vehicle outside of warranty carry a 'fitted in service' parts warranty.

Ford diagnostics For speedy and accurate fault diagnosis, we provide a sophisticated, internet-linked vehicle diagnostics system.

Ford trained technicians Ford commercial vehicle dealers have Ford-trained technicians, supported by online technical information and a Ford technical hotline.

Unscheduled repairs When your commercial vehicles aren't working, neither are your drivers. Our priority is to get your vehicle back on the road as quickly and as efficiently as possible.

Priority treatment for urgent repairs Initial diagnosis on urgent (vehicle off-road) repairs is carried out on arrival, with parts ordered within two hours of arrival – especially helpful when a replacement vehicle won't do. We aim to complete most repairs the same working day.

Dedicated backup from Ford

Ford Fleet Electronic Recall Programme This simplifies the process of recalls and improves communications with the operators of affected vehicles.

Ford Fleet Service Centre A dedicated team of experienced service advisors to assist with your aftersales issues.

Ford Fleet Accident Management Whatever the make of the vehicle, we offer a free, ethical and comprehensive accident management programme.

Efficiency, accuracy and convenience are at the heart of the Ford Transit24 commercial vehicle service promise. So, whether it's servicing, maintenance or repair you need, be sure to come and see us.

For more information and to find your nearest Transit Service Dealer, visit the aftersales support section at www.ford.co.uk/fordfleet

Commercial Vehicle Finance

When it comes to financing your Ford Commercial Vehicle, our size and expertise means we're well placed to provide you with a wide range of finance products.

Ford Credit*: Provides a range of finance plans for Commercial Vehicle customers interested in owning their vehicle.

Ford Lease^: Specialises in contract hire and leasing and provides an alternative range of finance plans which can be tailored to suit your business. Business users only.

Important Information:

*Ford Credit: Finance subject to status. Guarantees may be required. Freepost Ford Credit.

Ford Credit is a trading style of FCE Bank plc, which is authorised by the Prudential Regulation Authority and regulated by the Financial Conduct Authority and Prudential Regulation Authority under firm reference number 204469.

^Ford Lease: Ford Lease is provided by ALD Automotive Ltd, trading as Ford Lease, BS16 3JA. ALD Automotive is registered in England No. 987418. For the purposes of the Data Protection Act 1998 the data controllers in relation to any information you supply are Ford Motor Company Limited, FCE Bank Plc and ALD Automotive. Finance subject to status. Guarantees and indemnities may be required. ALD Automotive is authorised and regulated by the Financial Conduct Authority in respect of general insurance products. Ford Lease is a registered trademark of Ford Motor Company Limited.

Services

To find the location of your nearest Transit Centre simply visit the Ford Dealer locator at www.fordvans.co.uk

Ford Warranty Every new Ford Fiesta Van and Ford Ranger is protected by a 3-year/ 60,000 mile* warranty^o.

Ford Transit, Transit/Tourneo Custom, Transit/Tourneo Connect and Transit Courier are protected by a 3-year/100,000 mile warranty^o.

Ford Transit Chassis Cab One-Stop bodywork is covered by a 3-year/ 100,000 mile warranty^o and a 3-year Perforation Warranty provided by the bodywork supplier.

Ford Perforation Warranty Ford Ranger, Transit, Transit/Tourneo Custom, Transit/Tourneo Connect, Transit Courier and Fiesta Van are covered by the Ford Perforation Warranty^o for 12 years from the date of first registration. Please see your Ford Transit Specialist Dealer for details.

Ford Assistance Ford Transit, Transit Custom, Transit Connect and Ranger are supplied with a minimum of a 1-year Ford Assistance roadside package. Further details are available either on www.ford.co.uk or from your local Ford Dealer.

Ford Accident Repair Centres Approved Ford Accident Repair Centres meet rigorous Ford standards and are the best place to return your vehicle to its pre-accident condition.

Contacts

Ford Customer Relationship Centre In the unlikely event that your Ford Dealer can't help you or if you need to speak to us directly, call 0203 564 4444 at local rates.

Ford Rental – local service nationwide Car and Van rental from our latest model range. Contact your local Ford Dealer for more information.

Ford Motability Call our Ford Motability team on 0345 6040019

* year 1 - unlimited mileage

^o Subject to terms and conditions

Colour and trim

Choose the body colour that you think best reflects your business brand.

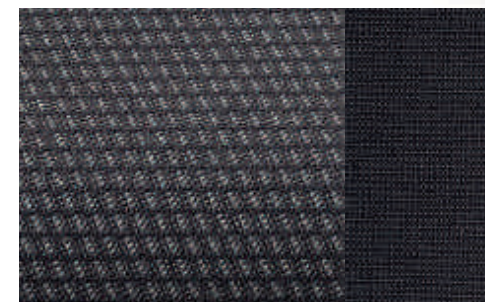

Base

Traxon seat insert in Charcoal Black
Max seat bolsters in Charcoal Black

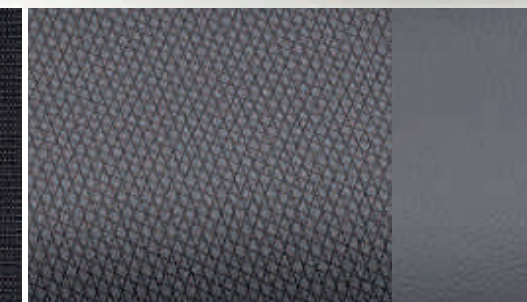

Base

Artec Vinyl seat insert in Pewter
Prima Vinyl seat bolsters in Pewter

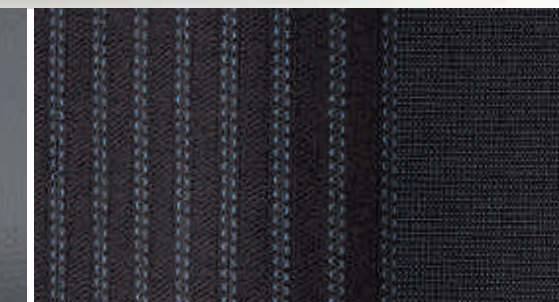

Trend

Lane seat insert in Charcoal Black
Max seat bolsters in Charcoal Black

Allergy-friendly interior

The Transit interior uses materials that minimise the risk of an allergic reaction. Models fitted with air conditioning also have a high-performance pollen filter to prevent dust and pollen entering the passenger compartment.



Frozen White
Solid body colour



Race Red
Solid body colour



Blazer Blue
Solid body colour



Tectonic Silver
Metallic body colour*



Stratosphere
Metallic body colour*



Deep Impact Blue
Metallic body colour*



Magnetic
Metallic body colour*



Moondust Silver
Metallic body colour*



Lunar Sky
Metallic body colour*



Shadow Black
Mica body colour*

Special Vehicle Options (SVO)

While the Ford Commercial Vehicle range already offers an extensive choice of off-the-shelf features and options, the Special Vehicle Options (SVO) programme goes a step further. Practical options range from heavy-duty batteries to a choice of over 100 colours to match your company's livery.

For more information, please speak to your local Transit Centre.

*Metallic and Mica body colours are options at extra cost.
The Ford Transit is covered by the Ford Corrosion Protection Warranty for 12 years from the date of first registration. Subject to terms and conditions.
Note The vehicle images used are to illustrate body colours only and may not reflect current specification. Colours and trims reproduced within this brochure may vary from the actual colours, due to the limitations of the printing processes used.

Note: 180° rear cargo door hinge design appearance to change in Q3 2017.

12-year perforation warranty

The new Transit owes its durable exterior to a thorough multi-stage painting process. From the wax-injected steel body sections to the hard-wearing top coat, new materials and application processes ensure it will retain its good looks for many years to come.

Zinc coating Phosphate coat Electrocoat Top coat Clearcoat (not with Frozen White body colour)





MY 2017.5 GBR en

Illustrations, descriptions and specifications. This catalogue was correct at the time of going to print. However, Ford policy is one of continuous product development. The right is reserved to change specifications, colours and prices of the models and items illustrated and described in this publication at any time. For the latest details always consult your Ford Dealer. **Optional equipment.** Throughout this publication, wherever a feature is described as being an 'Option' or 'Option Fitment/Pack' etc, you should assume that it will be at extra cost to the base vehicle, unless specifically stated to the contrary. All models and colour combinations are subject to availability. **Note.** Some images portrayed are of a pre-production model and/or are computer generated, therefore, the design/features on the final version of the vehicle may differ in various respects. In addition, some of the features shown on the vehicles may be optional. **Note.** This brochure contains both original Ford accessories as well as a range of products from our suppliers. **+**The identified accessories are carefully selected third party supplier branded accessories which do not come with a Ford warranty but are covered by the third party supplier's own warranty, the details of which can be obtained from your Ford Dealer. **Note.** The Bluetooth® word mark and logos are owned by the Bluetooth SIG, Inc. and any use of such marks by Ford Motor Company is under licence. The iPod word mark and logos are the property of Apple Inc. Other trademarks and trade names are those of their respective owners. **Note.** Some driver assistance features and safety features described in this brochure are designed to function using sensors, whose performance may be affected under certain weather or environmental conditions.

The Government fuel figures do not express or imply any guarantee of the fuel consumption of any particular vehicle. The vehicles themselves have not been tested and there are inevitably differences between individual vehicles of the same model. In addition, a vehicle may incorporate particular modifications. Furthermore, the driver's style and road and traffic conditions, as well as the extent to which the vehicle has been driven and the standard of maintenance, will affect its fuel consumption. **Insurance groups** are only as recommended by the Association of British Insurers. You should always consult your insurance adviser for confirmation.



Ford and BP – working together to reduce fuel consumption and emissions.



A Smarter Way to Move.

Learn more at fordpass.co.uk



When you have finished with this brochure please recycle it.

Ford One Call

In the unlikely event that your Ford Dealer can't help you or if you need to speak to us directly, call 0203 564 4444

Ford Rental - local service nationwide

Car and Van rental from our latest model range. Contact your local Ford Dealer for more information

Ford Motability

Call our Ford Motability team on 0345 6040019

Finance

Ford Credit Customer Services 0345 712 5490
 Ford Lease Customer Services 0345 600 1405
 Calls to 0344 and 0345 numbers are charged at the same rate as a standard 01 or 02 geographic number, even when calling from a mobile.

Published by Ford Motor Company Limited, Brentwood, Essex, England. Registered in England No. 235446.

FA 1575/6
 BJN 205327. FoE H57E.
 PN 777502/0517/10m/GBR en
 May 2017.

© Ford Motor Company Limited.

www.ford.co.uk